

**Lecture 16:**

# **Parallel Programming on Graphs + How Memory Works**

---

**Parallel Computing  
Stanford CS149, Fall 2020**

# Today's topics

- **Programming abstractions for processing graphs**
  - **More examples of “domain-specific” programming systems**
- **Common optimizations when processing graphs**
- **How memory (DRAM) works**
  - **Today is a good lecture to talk about memory since graph algorithms are often bandwidth bound!**

# Last time: increasing acceptance of domain-specific programming systems

- **Challenge to programmers: modern computers are parallel, heterogeneous machines (HW architects striving for high area and power efficiency)**
- **Trend: domain-specific programming systems: give up generality in what programs can be expressed, in exchange for achieving high productivity and high performance**
- **“Performance portability” is a key goal: programs should execute efficiently on a variety of parallel platforms**
  - **Good implementations of same program for different systems require different data structures, algorithms, and approaches to parallelization — not just differences in low-level code generation (optimization is not only a matter of generating SSE vs. AVX vs ARM Neon vs. NVIDIA PTX instructions)**

# Today's topic: analyzing big graphs

- **Many modern applications:**

- **Web search results, recommender systems, influence determination, advertising, anomaly detection, etc.**

- **Public dataset examples:**

**Twitter social graph, Wikipedia term occurrences, IMDB actors, Netflix, Amazon communities**

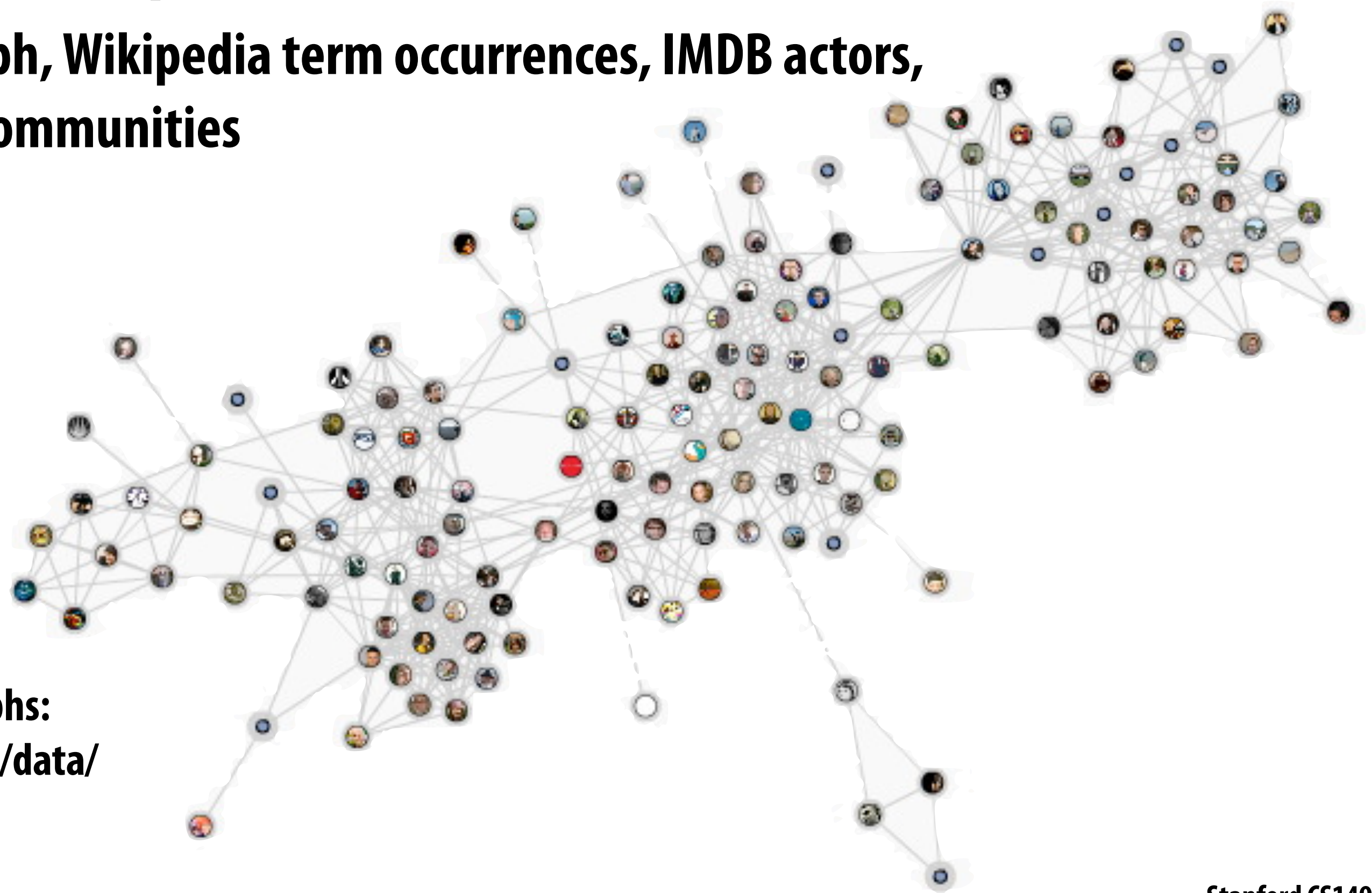

**Good source of public graphs:  
<https://snap.stanford.edu/data/>**

**Thought experiment: if we wanted to design a programming system for computing on graphs, where might we begin?**

**What abstractions do we need?**

# Whenever I'm trying to assess a new programming system, I ask two questions:

**“What tasks/problems does the system take off the programmer's hands? (are these problems challenging or tedious enough that I feel the system is adding sufficient value for me to want to use it?)”**

**“What problems does the system leave as the responsibility for the programmer?” (usually because the programmer is better at these tasks)**

**Halide (recall previous class):**

**Programmer's responsibility:**

- Describing image processing algorithm as pipeline of operations on images
- Describing the schedule for executing the pipeline (e.g., “block this loop, “parallelize this loop”, “fuse these stages”)

**Halide system's responsibility:**

- Implementing the schedule using mechanisms available on the target machine (spawning pthreads, allocating temp buffers, emitting vector instructions, loop indexing code)

# Programming system design questions:

- **What are the fundamental operations we want to be easy to express and efficient to execute?**
- **What are the key optimizations used when authoring the best implementations of these operations by hand?  
(high-level abstractions provided by a programming system should not stand in the way of these optimizations... maybe even allow the system to perform them for the programmer)**

# Example graph computation: Page Rank

Page Rank: iterative graph algorithm

Graph nodes = web pages

Graph edges = links between pages

$$R[i] = \frac{1 - \alpha}{N} + \alpha \sum_{j \text{ links to } i} \frac{R[j]}{\text{Outlinks}[j]}$$

Rank of page  $i$

discount

Weighted combination of rank of pages that link to it



# GraphLab

- A system for describing iterative computations on graphs
- Implemented as a C++ library
- Runs on shared memory machines or distributed across clusters
  - **GraphLab runtime takes responsibility for scheduling work in parallel, partitioning graphs across clusters of machines, communication between master, etc.**

# GraphLab programs: state

## ■ The graph: $G = (V, E)$

- Application defines data blocks on each vertex and directed edge
- $D_v =$  data associated with vertex  $v$
- $D_{u \rightarrow v} =$  data associated with directed edge  $u \rightarrow v$

## ■ Read-only global data

- Can think of this as per-graph data, rather than per vertex or per-edge data)

**Notice: I always first describe program state**

**And then describe what operations are available to manipulate this state**

# GraphLab operations: the “vertex program”

- Defines per-vertex operations on the vertex’s local neighborhood
- Neighborhood (aka “scope”) of vertex:

- The current vertex
- Adjacent edges
- Adjacent vertices

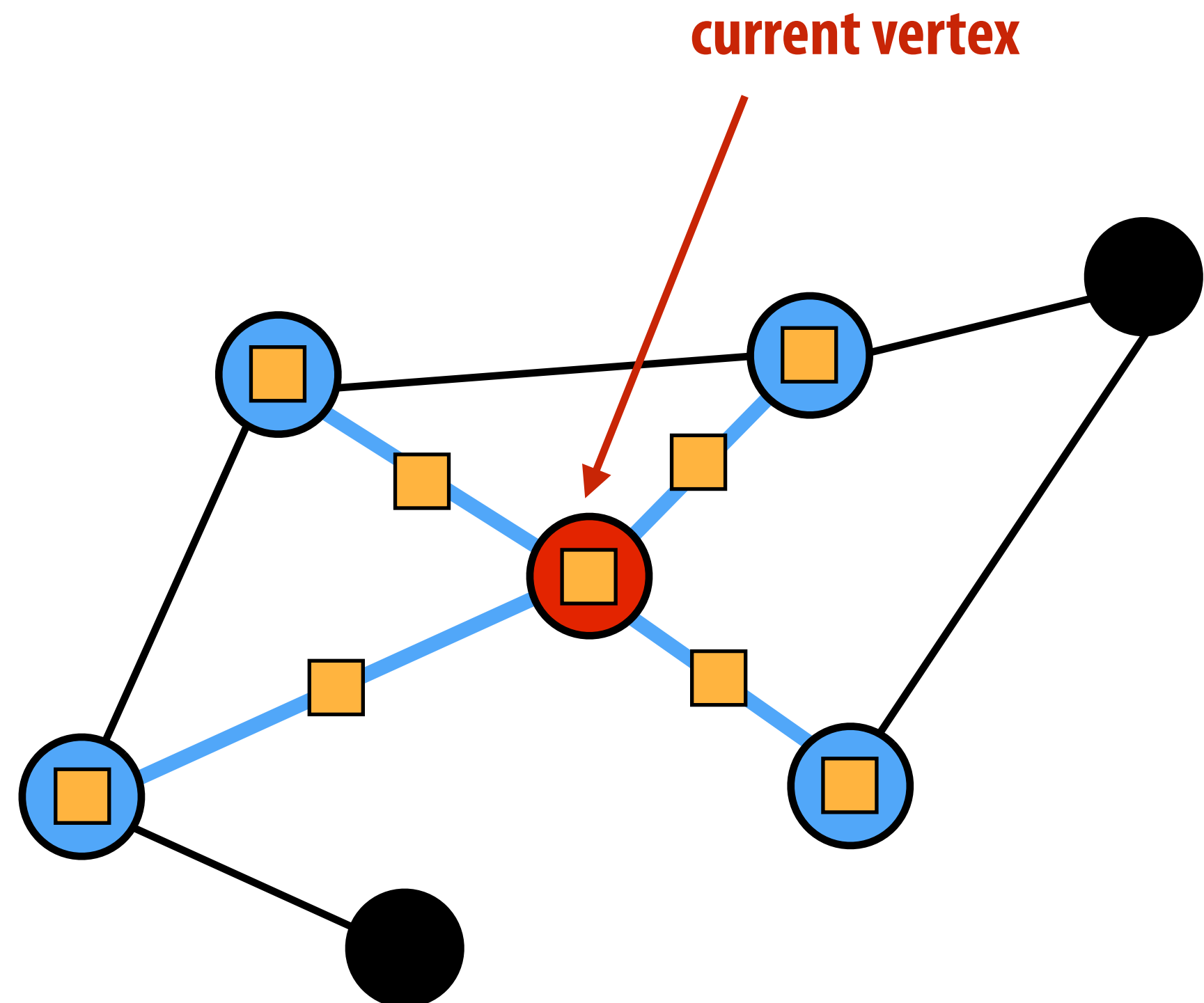

 = vertex or edge data “in scope” of red vertex  
(graph data that can be accessed when executing  
a vertex program at the current (red) vertex)

# Simple example: PageRank \*

$$R[i] = \frac{1 - \alpha}{N} + \alpha \sum_{j \text{ links to } i} \frac{R[j]}{\text{Outlinks}[j]}$$

```
PageRank_vertex_program(vertex i) {
```

```
    // (Gather phase) compute the sum of my neighbors rank
```

```
    double sum = 0;
```

```
    foreach(vertex j : in_neighbors(i)) {
```

```
        sum = sum + j.rank / num_out_neighbors(j);
```

```
    }
```

```
    // (Apply phase) Update my rank (i)
```

```
    i.rank = (1-0.85)/num_graph_vertices() + 0.85*sum;
```

```
}
```

Let alpha = 0.85

**Programming in GraphLab amounts to defining how to update graph state at each vertex. The system takes responsibility for scheduling and parallelization.**

\* This is made up syntax for slide simplicity: actual syntax is C++, as we'll see on the next slide

# GraphLab: data access

- **The application's vertex program executes per-vertex**
- **The vertex program defines:**
  - **What adjacent edges are inputs to the computation**
  - **What computation to perform per edge**
  - **How to update the vertex's value**
  - **What adjacent edges are modified by the computation**
  - **How to update these output edge values**
- **Note how GraphLab requires the program to tell it all data that will be accessed, and whether those accesses are reads or writes**

# PageRank: GraphLab vertex program (C++ code)

```
struct web_page {  
    std::string pagename;  
    double pagerank;  
    web_page(): pagerank(0.0) { }  
}
```

```
typedef graphlab::distributed_graph<web_page, graphlab::empty> graph_type;
```

```
class pagerank_program : public graphlab::ivertex_program {
```

```
public:
```

```
// we are going to gather over all the in-edges  
edge_dir_type gather_edges(icontext_type& context,  
                            const vertex_type& vertex) const {  
    return graphlab::IN_EDGES;  
}
```

```
// for each in-edge gather the weighted sum of the edge.  
double gather(icontext_type& context, const vertex_type& vertex,  
              edge_type& edge) const {  
    return edge.source().data().pagerank / edge.source().num_out_edges();  
}
```

```
// Use the total rank of adjacent pages to update this page  
void apply(icontext_type& context, vertex_type& vertex,  
           const gather_type& total) {  
    double newval = total * 0.85 + 0.15;  
    vertex.data().pagerank = newval;  
}
```

```
// No scatter needed. Return NO_EDGES  
edge_dir_type scatter_edges(icontext_type& context,  
                             const vertex_type& vertex) const {  
    return graphlab::NO_EDGES;  
}  
};
```

Graph has record of type web\_page per vertex, and no data on edges

Define edges to gather over in "gather phase"

Compute value to accumulate for each edge

Update vertex rank

PageRank example performs no scatter

# Running the program

```
graphlab::omni_engine<pagerank_program> engine(dc, graph, "sync");  
engine.signal_all();  
engine.start();
```

**GraphLab runtime provides “engines” that manage scheduling of vertex programs**  
**engine.signal\_all() marks all vertices for execution**

**You can think of the GraphLab runtime as a work queue scheduler.**

**Invoking a vertex program on a specific vertex is a task that is placed in the work queue.**

**So it is reasonable to read the code above as: “place all vertices into the work queue”**

**Or as: “foreach vertex” run the vertex program.**



# Vertex signaling: GraphLab's mechanism for generating new work

$$R[i] = \frac{1 - \alpha}{N} + \alpha \sum_{j \text{ links to } i} \frac{R[j]}{\text{Outlinks}[j]}$$

Iteratively update all  $R[i]$ 's 10 times

Uses generic "signal" primitive (could also wrap code on previous slide in a for loop)

```
struct web_page {
  std::string pagename;
  double pagerank;
  int counter;
  web_page(): pagerank(0.0), counter(0) { }
}
```

Per-vertex "counter"



```
// Use the total rank of adjacent pages to update this page
void apply(icontext_type& context, vertex_type& vertex,
           const gather_type& total) {
  double newval = total * 0.85 + 0.15;
  vertex.data().pagerank = newval;
  vertex.data().counter++;
  if (vertex.data().counter < 10)
    vertex.signal();
}
```

If counter < 10, signal to scheduler to run the vertex program on the vertex again at some point in the future



# Signal: general primitive for scheduling work

Parts of graph may converge at different rates

(iterate PageRank until convergence, but only for vertices that need it)

```
class pagerank_program: public graphlab::ivertex_program
```

```
private:
```

```
    bool perform_scatter;
```



Private variable set during apply phase,  
used during scatter phase

```
public:
```

```
    // Use the total rank of adjacent pages to update this page  
    void apply(icontext_type& context, vertex_type& vertex,
```

```
               const gather_type& total) {
```

```
        double newval = total * 0.85 + 0.15;
```

```
        double oldval = vertex.data().pagerank;
```

```
        vertex.data().pagerank = newval;
```

```
        perform_scatter = (std::fabs(prevval - newval) > 1E-3);
```



Check for convergence

```
    }
```

```
    // Scatter now needed if algorithm has not converged  
    edge_dir_type scatter_edges(icontext_type& context,
```

```
                                const vertex_type& vertex) const {
```

```
        if (perform_scatter) return graphlab::OUT_EDGES;
```

```
        else return graphlab::NO_EDGES;
```

```
    }
```

```
    // Make sure surrounding vertices are scheduled  
    void scatter(icontext_type& context, const vertex_type& vertex,
```

```
                edge_type& edge) const {  
        context.signal(edge.target());
```

```
    }
```

```
};
```

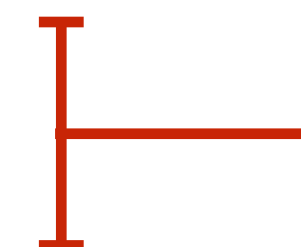

Schedule update of  
neighbor vertices

# Synchronizing parallel execution

Local neighborhood of vertex (vertex's "scope") can be read and written to by a vertex program

Programs specify what granularity of atomicity they want GraphLab to provide: this determines amount of available parallelism

- **"Full"**: implementation ensures no other execution reads or writes to data in scope of  $v$  when vertex program for  $v$  is running.
- **"Edge"**: no other execution reads or writes any data in  $v$  or in edges adjacent to  $v$
- **"Vertex"**: no other execution reads or writes to data in  $v$  ...

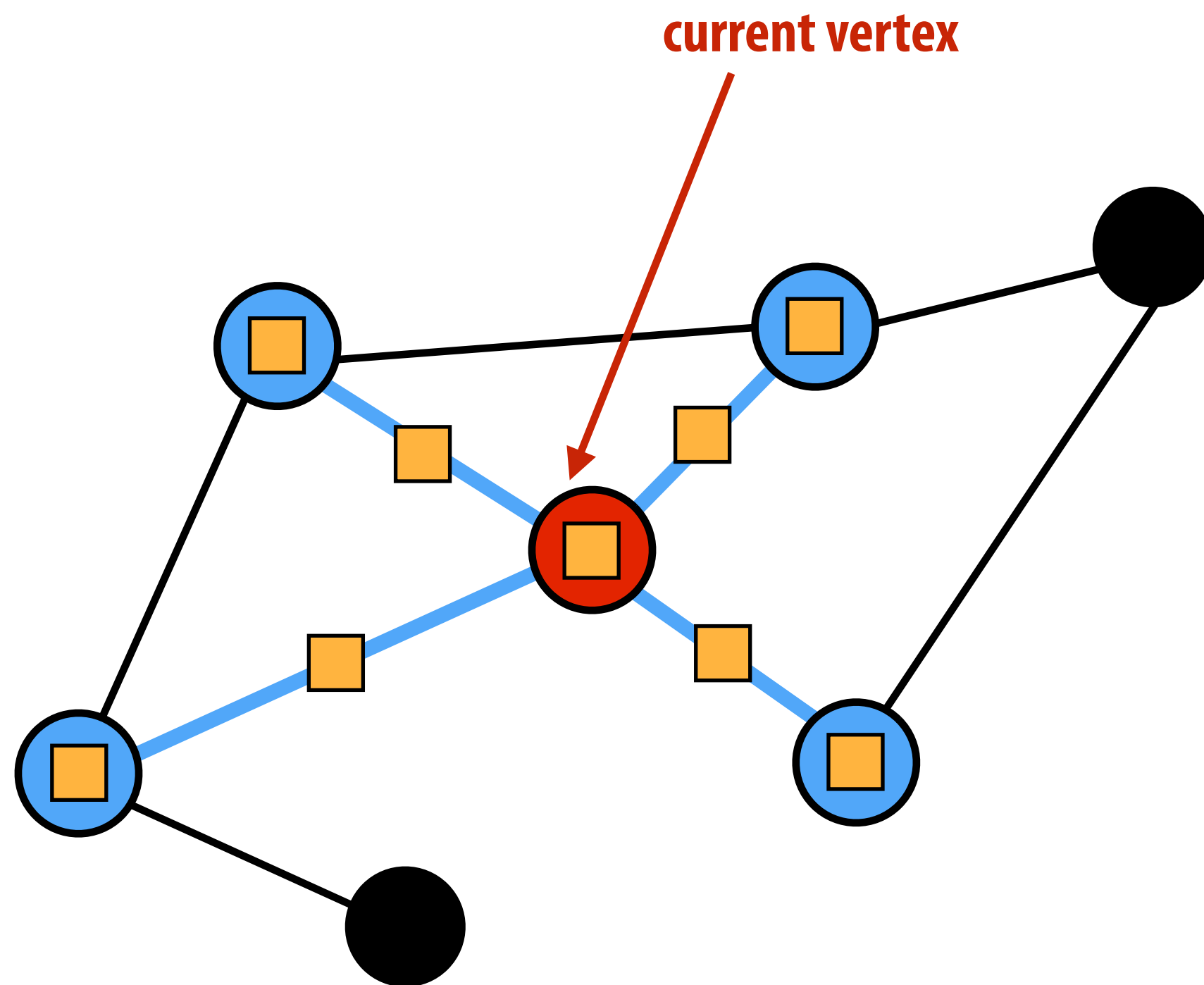

 = vertex or edge data in scope of red vertex

# GraphLab: work scheduling order

- **GraphLab implements several work scheduling policies**
  - **Synchronous: update all vertices simultaneously (vertex programs observe no updates from programs run on other vertices in same “round”)**
  - **Round-robin: vertex programs observe most recent updates**
  - **Dynamic: based on new work created by `signal`**
    - **Several implementations: `fifo`, `priority-based`, “`splash`” ...**
- **Application developer has flexibility for choosing atomicity guarantee and scheduling policy**
  - **Implication: choice of schedule impacts program’s correctness/output**

# Summary: GraphLab concepts

- **Program state: data on graph vertices and edges + globals**
- **Operations: per-vertex update programs and global reduction functions (reductions not discussed today)**
  - **Simple, intuitive description of work (follows mathematical formulation)**
  - **Graph restricts data access in vertex program to local neighborhood**
  - **Asynchronous execution model: application creates work dynamically by “signaling vertices” (enable lazy execution, work efficiency on real graphs)**
- **Choice of scheduler and atomicity implementation**
  - **In this domain, the order in which nodes are processed can be critical property for both performance and quality of result**
  - **Application responsible for choosing right scheduler for its needs**

# **Ligra**

**(efficient data-parallel graph processing  
for shared memory multi-cores)**

- A simple framework for parallel graph operations on shared memory multi-core machines
- Motivating example: breadth-first search

```
parents = {-1, ..., -1}
```

```
// s = src: vertex on frontier with edge to d  
// d = dst: vertex to "update" (just encountered)  
procedure UPDATE(s, d)  
    return compare-and-swap(parents[d], -1, s);
```

```
procedure COND(i)  
    return parents[i] == -1;
```

```
procedure BFS(G, root)  
    parents[root] = root;  
    frontier = {root};  
    while (size(frontier) != 0) do:  
        frontier = EDGEMAP(G, frontier, UPDATE, COND);
```

**Semantics of EDGEMAP:**

foreach vertex  $i$  in frontier, call UPDATE for all neighboring vertices  $j$  for which COND( $j$ ) is true. Add  $j$  to returned set if UPDATE( $i, j$ ) returns true

# Implementing edgemap

- Assume vertex subset  $U$  (frontier in previous example) is represented sparsely:

- e.g., three vertex subset  $U$  of 10 vertex graph  $G=(E,V)$ :  $U \subset V = \{0, 4, 9\}$

```
procedure EDGEMAP_SPARSE(G, U, F, C):  
  result = {}  
  parallel foreach v in U do:  
    parallel foreach v2 in out_neighbors(v) do:  
      if (C(v2) == 1 and F(v,v2) == 1) then  
        add v2 to result  
  remove duplicates from result  
  return result;
```

graph

set of vertices

condition check on neighbor vertex

update function on neighbor vertex

**Cost of EDGEMAP\_SPARSE?**

**$O(|U| + \text{sum of outgoing edges from } U)$**

```
parents = {-1, ..., -1}  
  
procedure UPDATE(s, d)  
  return compare-and-swap(parents[d], -1, s);  
  
procedure COND(i)  
  return parents[i] == -1;  
  
procedure BFS(G, r)  
  parents[r] = r;  
  frontier = {r};  
  while (size(frontier) != 0) do:  
    frontier = EDGEMAP(G, frontier, UPDATE, COND);
```



# Visiting every edge on frontier can be wasteful

- Each step of BFS, every edge on frontier is visited
  - Frontier can grow quickly for social graphs (few steps to visit all nodes)
  - Most edge visits are wasteful! (they don't lead to a successful "update")

- **claimed child**: edge points to unvisited vertex (useful work)
- **failed child**: edge points to vertex found in this step via another edge
- **peer**: edge points to a vertex that was added to frontier in same step as current vertex
- **valid parent**: edge points to vertex found in previous step

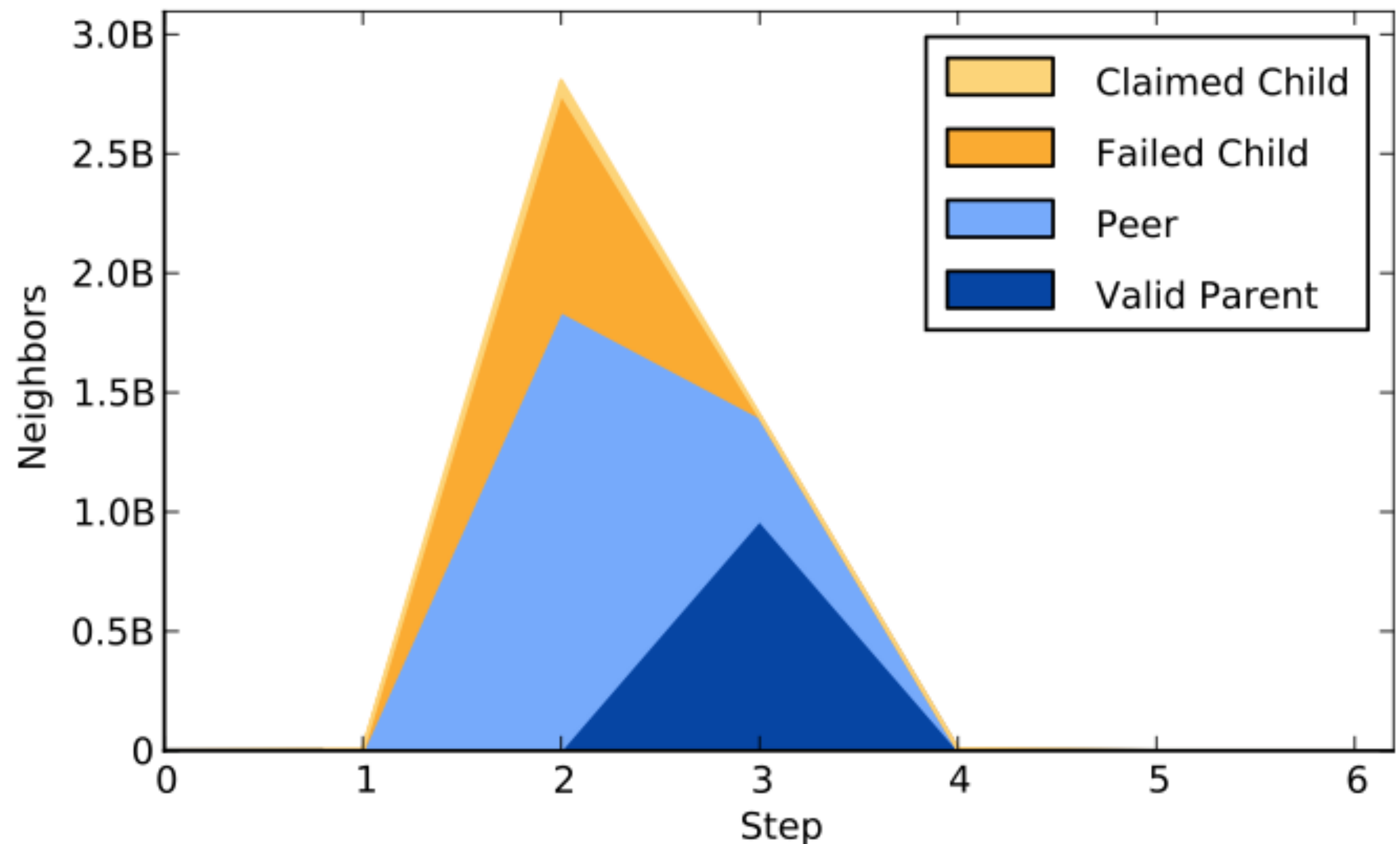

[Credit: Beamer et al. SC12]

# Implementing edgemap for dense vertex subsets

- Assume vertex subset (frontier in previous example) is represented densely with a bitvector:

- e.g., vertex subset  $U$  of 10 vertex graph  $G=(E,V)$ :  $U \subset V = \{1,0,0,0,1,0,0,0,0,1\}$

```
procedure EDGEMAP_SPARSE(G, U, F, C):  
  result = {}  
  parallel foreach v in U do:  
    parallel foreach v2 in out_neighbors(v) do:  
      if (C(v2) == 1 and F(v,v2) == 1) then  
        add v2 to result  
  remove duplicates from result  
  return result;
```

```
procedure EDGEMAP_DENSE(G, U, F, C):  
  result = {}  
  parallel for i in {0,...,|V|-1} do:  
    if (C(i) == 1) then:  
      foreach v in in_neighbors(i) do:  
        if v ∈ U and F(v, i) == 1 then:  
          add i to result;  
        if (C(i) == 0)  
          break;  
  return result;
```

## Cost of EDGEMAP\_DENSE?

For each unvisited vertex, quit searching as soon as some parent is found

Could be as low as  $O(|V|)$

Also no synchronization needed (“gather” results rather than “scatter”)

# Ligra on one slide

## ■ Entities:

- **Graphs**
- **Vertex subsets (represented sparsely or densely by system)**
- **EDGEMAP and VERTEXMAP functions**

```
procedure EDGEMAP(G, U, F, C):  
  if (|U| + sum of out degrees > threshold)  
    return EDGEMAP_DENSE(G, U, F, C);  
  else  
    return EDGEMAP_SPARSE(G, U, F, C);
```



**Iterate over all vertices adjacent to  
vertices in set U  
Choose right algorithm for the job**

```
procedure VERTEXMAP(U, F):  
  result = {}  
  parallel for u ∈ U do:  
    if (F(u) == 1) then:  
      add u to result;  
  return result;
```



**Iterate over all vertices in set U**

# Page rank in Ligra

```
r_cur = {1/|V|, ... 1/|V|};
```

```
r_next = {0, ..., 0};
```

```
diff = {}
```

```
procedure PRUPDATE(s, d):
```

```
    atomicIncrement(&r_next[d], r_cur[s] / vertex_degree(s));
```

```
procedure PRLOCALCOMPUTE(i):
```

```
    r_next[i] = alpha * r_next[i] + (1 - alpha) / |V|;
```

```
    diff[i] = |r_next[i] - r_cur[i]|;
```

```
    r_cur[i] = 0;
```

```
    return 1;
```

```
procedure COND(i):
```

```
    return 1;
```

```
procedure PAGERANK(G, alpha, eps):
```

```
    frontier = {0, ... , |V|-1}
```

```
    error = HUGE;
```

```
    while (error > eps) do:
```

```
        frontier = EDGEMAP(G, frontier, PRUPDATE, COND);
```

```
        frontier = VERTEXMAP(frontier, PRLOCALCOMPUTE);
```

```
        error = sum of per-vertex diffs // this is a parallel reduce
```

```
        swap(r_cur, r_next);
```

```
    return err
```

**Question: can you implement the iterate until convergence optimization we previously discussed in GraphLab?**

**(if so, what GraphLab scheduler implementation is the result equivalent to?)**

# Ligra summary

- **System abstracts graph operations as data-parallel operations over vertices and edges**
  - **Emphasizes graph traversal (potentially small subset of vertices operated on in a data parallel step)**
- **These basic operations permit a surprisingly wide space of graph algorithms:**
  - **Betweenness centrality**
  - **Connected components**
  - **Shortest paths**

See **Ligra: a Lightweight Framework for Graph Processing for Shared Memory [Shun and Blelloch 2013]**

# Ligra

Simple library with many useful examples

<http://jshun.github.io/ligra/>

- Introduction
- Getting Started
- Tutorial: BFS
- Tutorial: KCore
- API
  - Vertex
  - Graph
- Running Code
- Examples

## Examples

Implementation files are provided in the apps/ directory:

- **BFS.C** (breadth-first search)
- **BFS-Bitvector.C** (breadth-first search with a bitvector to mark visited vertices)
- **BC.C** (betweenness centrality)
- **Radii.C** (graph eccentricity estimation)
- **Components.C** (connected components)
- **BellmanFord.C** (Bellman-Ford shortest paths)
- **PageRank.C**
- **PageRankDelta.C**
- **BFSCC.C** (connected components based on BFS)
- **KCore.C** (computes k-cores of the graph)

## Eccentricity Estimation

Code for eccentricity estimation is available in the apps/eccentricity/ directory:

- **kBFS-Ecc.C** (2 passes of multiple BFS's)
- **kBFS-1Phase-Ecc.C** (1 pass of multiple BFS's)
- **FM-Ecc.C** (estimation using Flajolet-Martin counters; an implementation of a variant of HADI from *TKDD '11*)
- **LogLog-Ecc.C** (estimation using LogLog counters; an implementation of a variant of HyperANF from *WWW '11*)
- **RV.C** (parallel implementation of the algorithm by Roditty and Vassilevska Williams from *STOC '13*)
- **CLRSTV.C** (parallel implementation of a variant of the algorithm by Chechik, Larkin, Roditty, Schoenebeck, Tarjan, and Vassilevska Williams from *SODA '14*)
- **kBFS-Exact.C** (exact algorithm using multiple BFS's)
- **TK.C** (a parallel implementation of the exact algorithm by Takes and Kosters from *Algorithms '13*)
- **Simple-Approx-Ecc.C** (simple 2-approximation algorithm)

Follow the same instructions as above for compilation, but from the apps/eccentricity/ directory.

For kBFS-Ecc.C, kBFS-1Phase-Ecc.C, FM-Ecc.C, LogLog-Ecc.C, and kBFS-Exact.C, the "-r" flag followed by an integer indicates the maximum number of words to associate with each vertex. For all implementations, the "-s" flag should be used as the current implementations are designed for undirected graphs. To output the eccentricity estimates to a file, use the "-out" flag followed by the name of the output file. The file format is one integer per line, with the eccentricity estimate for vertex  $i$  on line  $i$ .

# **Elements of good domain-specific programming system design**

# #1: good systems identify the most important cases, and provide most benefit in these situations

- **Structure of code mimics the natural structure of problems in the domain**
  - **Halide: pixel-wise view of filters:  $\text{pixel}(x,y)$  computed as expression of these input pixel values**
  - **Graph processing algorithms: per-vertex operations**
- **Efficient expression: common operations are easy and intuitive to express**
- **Efficient implementation: the most important optimizations in the domain are performed by the system for the programmer**
  - **My experience: a parallel programming system with “convenient” abstractions that precludes best-known implementation strategies will almost always fail**



# #2: good systems are simple systems

- **They have a small number of key primitives and operations**
  - **Ligra: only two operations! (vertexmap and edgemap)**
  - **GraphLab: run computation per vertex, trigger new work by signaling**
    - **But GraphLab gets messy with all the scheduling options**
  - **Halide: a few scheduling primitives for describing loop nests**
  - **Hadoop: map + reduce**
- **Allows compiler/runtime to focus on optimizing these primitives**
  - **Provide parallel implementations, utilize appropriate hardware**
- **Common question that good architects ask: “do we really need that?”**  
**(can this concept be reduced to a primitive we already have?)**
  - **For every domain-specific primitive in the system: there better be a strong performance or expressivity justification for its existence**

# #3: good primitives compose

- **Composition of primitives allows for wide application scope, even if scope is limited to a domain**
  - e.g., frameworks discussed today support a wide variety of graph algorithms
  - Halide's loop ordering + loop interleaving schedule primitives allow for expression of wide range of schedules
- **Composition often allows optimization to generalizable**
  - If system can optimize A and optimize B, then it can optimize programs that combine A and B
- **Common sign that a feature should not be added (or added in a different way):**
  - The new feature does not compose with all existing features in the system
- **Sign of a good design:**
  - System ultimately is used for applications original designers never anticipated

# **Optimizing graph computations**

**(now we are talking about implementation)**

# Wait a minute...

- So far in this lecture, we've discussed issues such as parallelism, synchronization ...
- But you may recall from your assignment that graph processing is typically has low arithmetic intensity

Walking over edges accesses information from "random" graph vertices

VTune profiling results from Asst 4: Memory bandwidth bound!

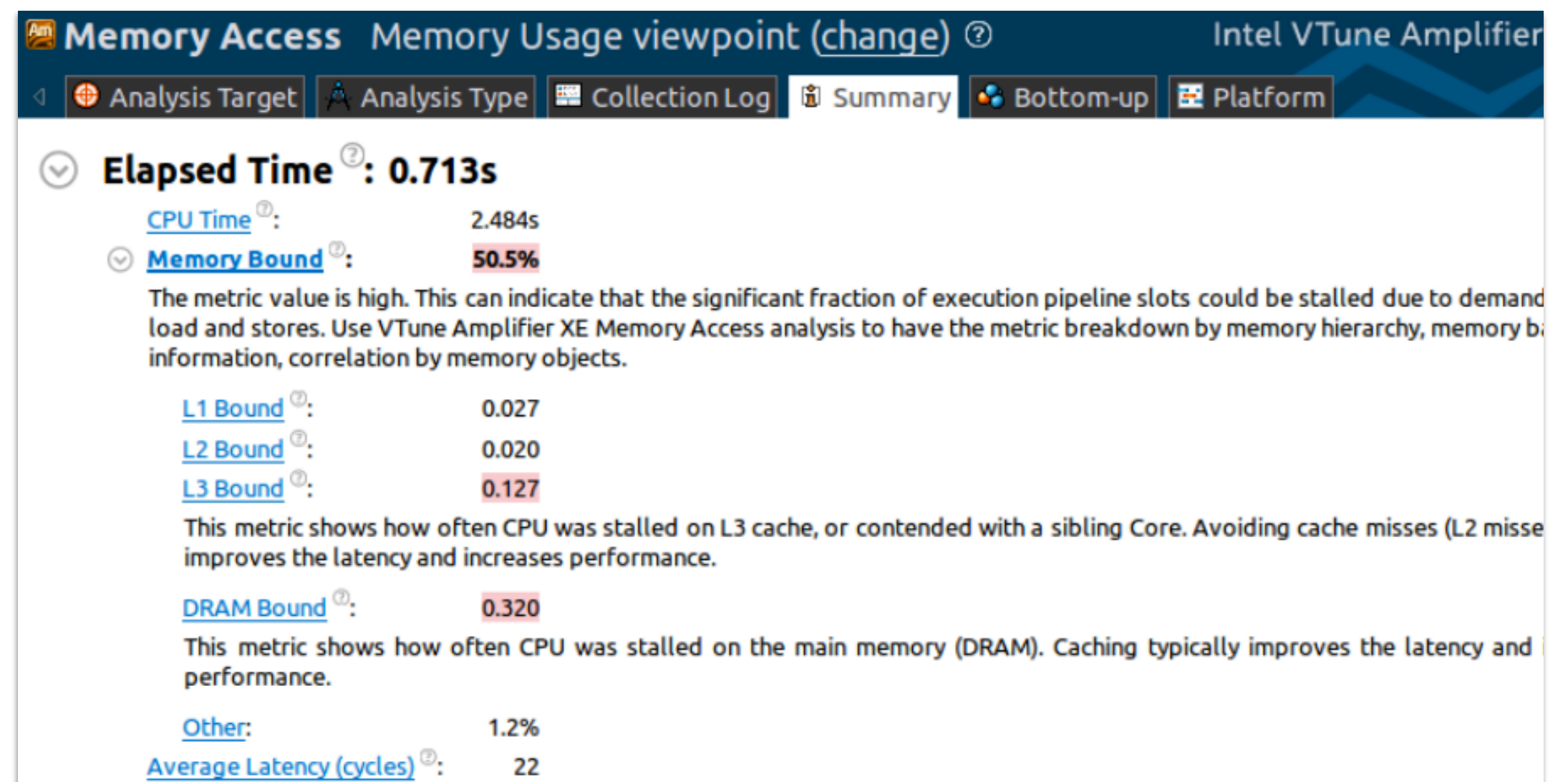

Or just consider PageRank: ~ 1 multiply-accumulate per iteration of summation loop

$$R[i] = \frac{1 - \alpha}{N} + \alpha \sum_{j \text{ links to } i} \frac{R[j]}{\text{Outlinks}[j]}$$

# Two ideas to increase the performance of operations on large graphs \*

1. Reorganize graph structure to increase locality
2. Compress the graph

\* Both optimizations might be performed by a framework without application knowledge

# Recall: directed graph representation

<b>Vertex Id</b>	<b>1</b>	<b>2</b>	<b>3</b>	<b>4</b>	<b>5</b>	<b>6</b>
<b>Outgoing Edges</b>	2 3	3 5	2 4 5 6	1 5	1 2 3 6	2 4

<b>Vertex Id</b>	<b>1</b>	<b>2</b>	<b>3</b>	<b>4</b>	<b>5</b>	<b>6</b>
<b>Incoming Edges</b>	4 5	1 3 5 6	1 2 5	3 6	2 3 4	3 6

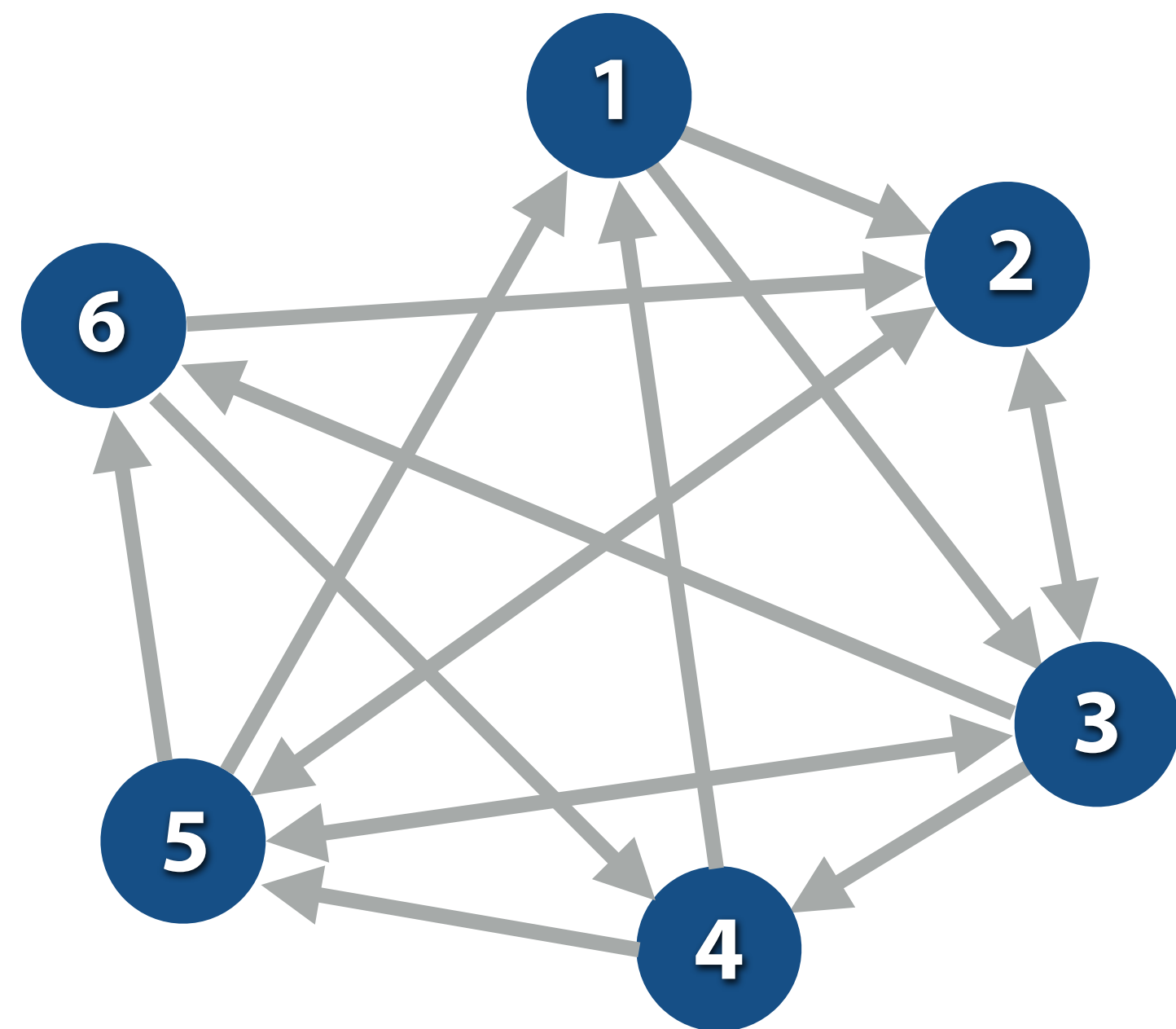

# Memory footprint challenge of large graphs

- **Challenge: cannot fit all edges in memory for large graphs**
  - Consider representation of graph from your programming assignment:
    - Each edge represented twice in graph structure (as incoming/outgoing edge)
    - 8 bytes per edge to represent adjacency
  - May also need to store per-edge values (e.g., 4 bytes for a per-edge weight)
  - 1 billion edges (modest): ~12 GB of memory for edge information
  - Algorithm may need multiple copies of per-edge structures (current, prev data, etc.)
- **Could employ cluster of machines to store graph in memory**
  - Rather than store graph on disk
- **Would prefer to process large graphs on a single machine**
  - Managing clusters of machines is difficult
  - Partitioning graphs is expensive (also needs a lot of memory) and difficult

# “Streaming” graph computations

- Graph operations make “random” access to graph data (edges adjacent to vertex  $v$  may be distributed arbitrarily throughout storage)
  - Single pass over graph’s edges might make billions of fine-grained accesses to disk

- Streaming data access pattern

- Make large, predictable data accesses to slow storage (achieve high bandwidth data transfer)
- Load data from slow storage into fast storage\*, then reuse it as much as possible before discarding it (achieve high arithmetic intensity)
- **Can we modify the graph data structure so that data access requires only a small number of efficient bulk loads/stores from slow storage?**

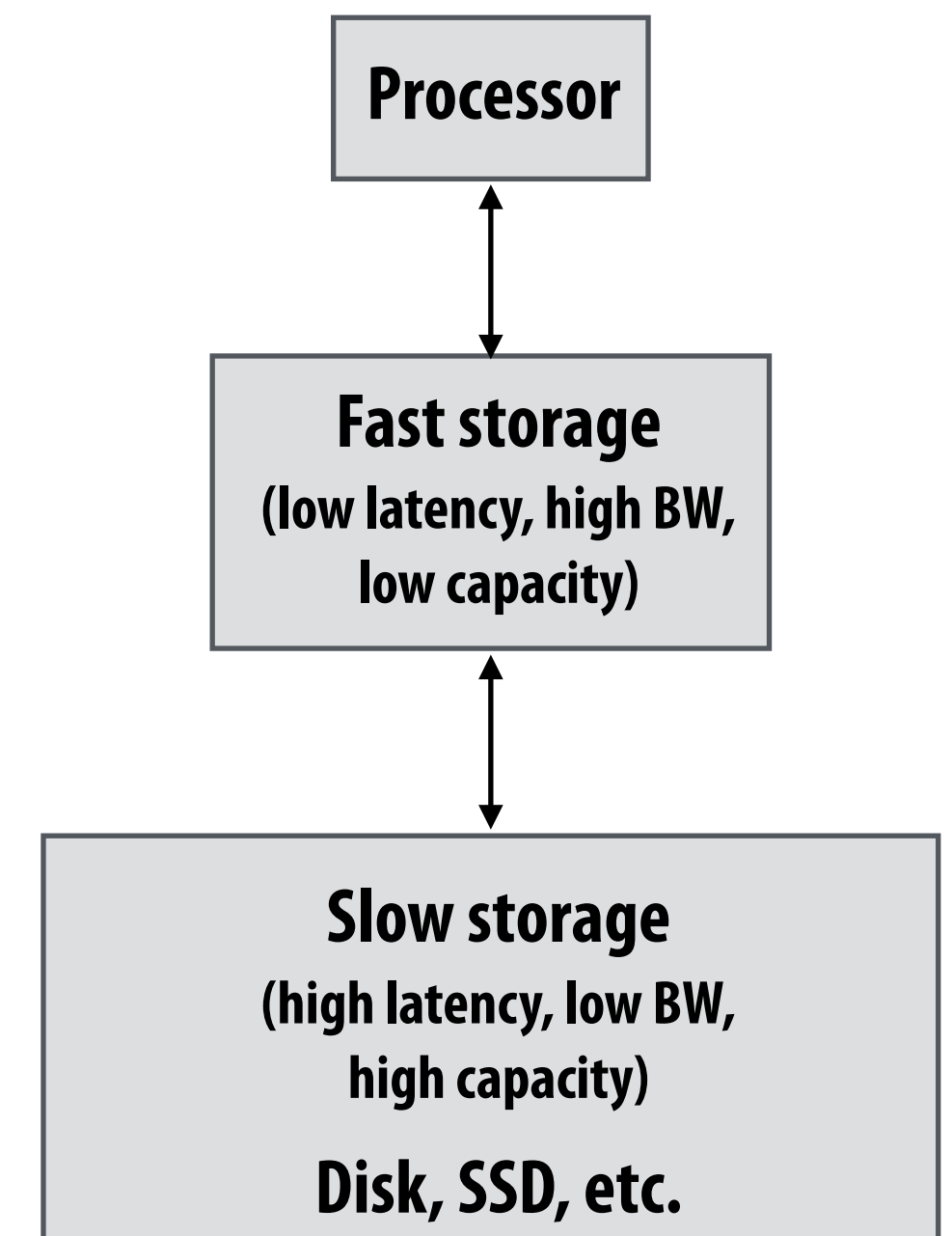

\* By fast storage, in this context I mean DRAM. However, techniques for streaming from disk into memory would also apply to streaming from memory into a processor’s cache



# Sharded graph representation

GraphChi: Large-scale graph computation on just a PC [Kryola et al. 2013]

- Partition graph vertices into intervals (sized so that subgraph for interval fits in memory)
- Vertices and only incoming edges to these vertices are stored together in a shard
- Sort edges in a shard by source vertex id

Shard 1: vertices (1-2)			Shard 2: vertices (3-4)			Shard 3: vertices (5-6)		
src	dst	value	src	dst	value	src	dst	value
1	2	0.3	1	3	0.4	2	5	0.6
3	2	0.2	2	3	0.9	3	5	0.9
4	1	0.8	3	4	0.15	4	6	0.85
5	1	0.25	5	3	0.2	5	6	0.3
	2	0.6	6	4	0.9	6	5	0.2
6	2	0.1						

Yellow = data required to process subgraph containing vertices in shard 1

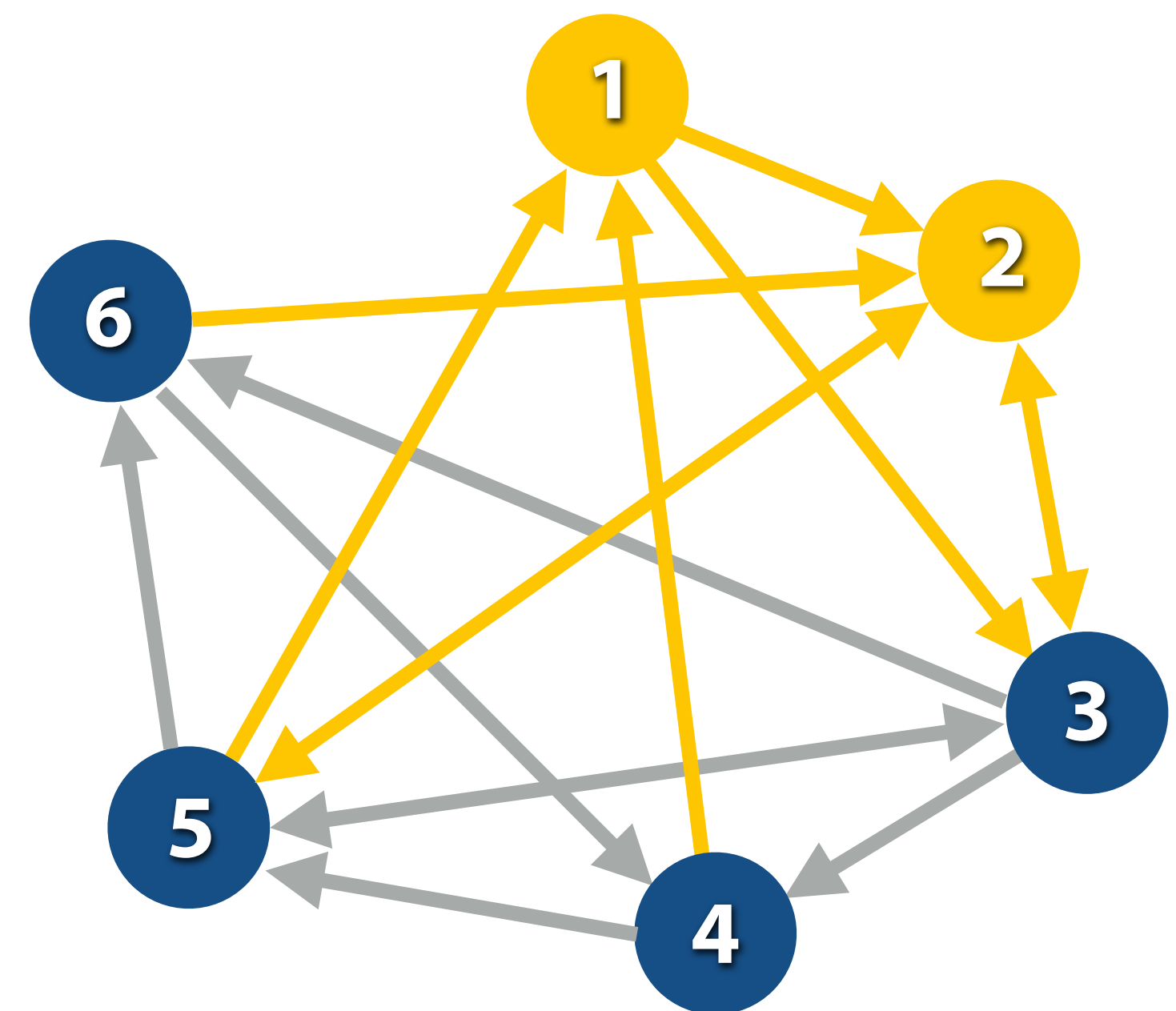

**Notice: to construct subgraph containing vertices in shard 1 and their incoming and outgoing edges, only need to load contiguous information from other P-1 shards**

**Writes to updated outgoing edges require P-1 bulk writes**

# Sharded graph representation

GraphChi: Large-scale graph computation on just a PC  
[Kryola et al. 2013]

- Partition graph vertices into intervals (sized so that subgraph for interval fits in memory)
- Vertices and only incoming edges to these vertices are stored together in a shard
- Sort edges in a shard by source vertex id

Shard 1: vertices (1-2)			Shard 2: vertices (3-4)			Shard 3: vertices (5-6)		
src	dst	value	src	dst	value	src	dst	value
1	2	0.3	1	3	0.4	2	5	0.6
3	2	0.2	2	3	0.9	3	5	0.9
4	1	0.8	3	4	0.15	6	5	0.85
5	1	0.25	5	3	0.2	4	5	0.3
	2	0.6	6	4	0.9	5	6	0.2
6	2	0.1						

Yellow = data required to process subgraph containing vertices in shard 2

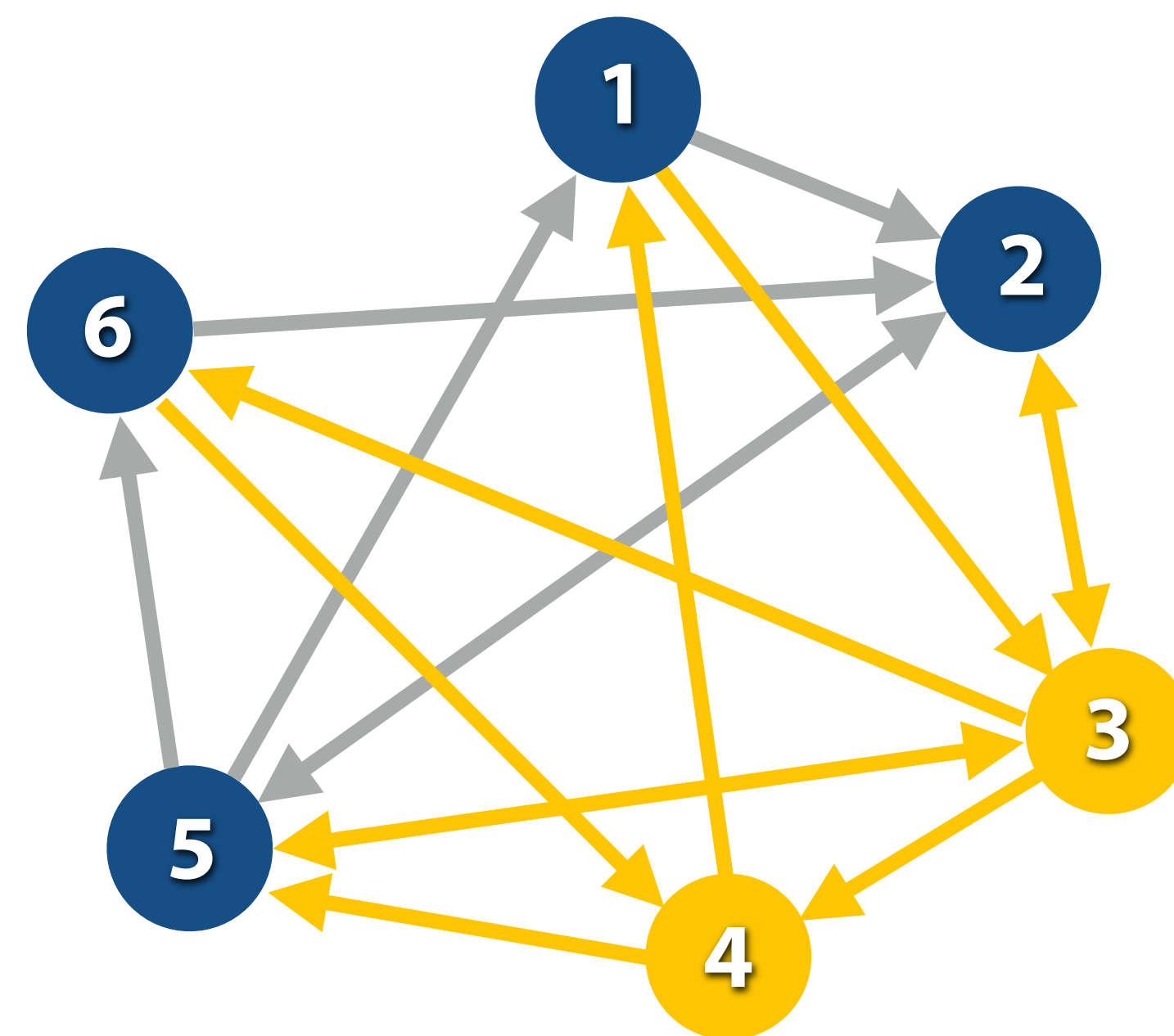

# Sharded graph representation

GraphChi: Large-scale graph computation on just a PC  
[Kryola et al. 2013]

- Partition graph vertices into intervals (sized so that subgraph for interval fits in memory)
- Vertices and only incoming edges to these vertices are stored together in a shard
- Sort edges in a shard by source vertex id

Shard 1: vertices (1-2)			Shard 2: vertices (3-4)			Shard 3: vertices (5-6)		
src	dst	value	src	dst	value	src	dst	value
1	2	0.3	1	3	0.4	2	5	0.6
3	2	0.2	2	3	0.9	3	5	0.9
4	1	0.8	3	4	0.15		6	0.85
5	1	0.25	5	3	0.2	4	5	0.3
	2	0.6	6	4	0.9	5	6	0.2
6	2	0.1						

Yellow = data required to process subgraph containing vertices in shard 3

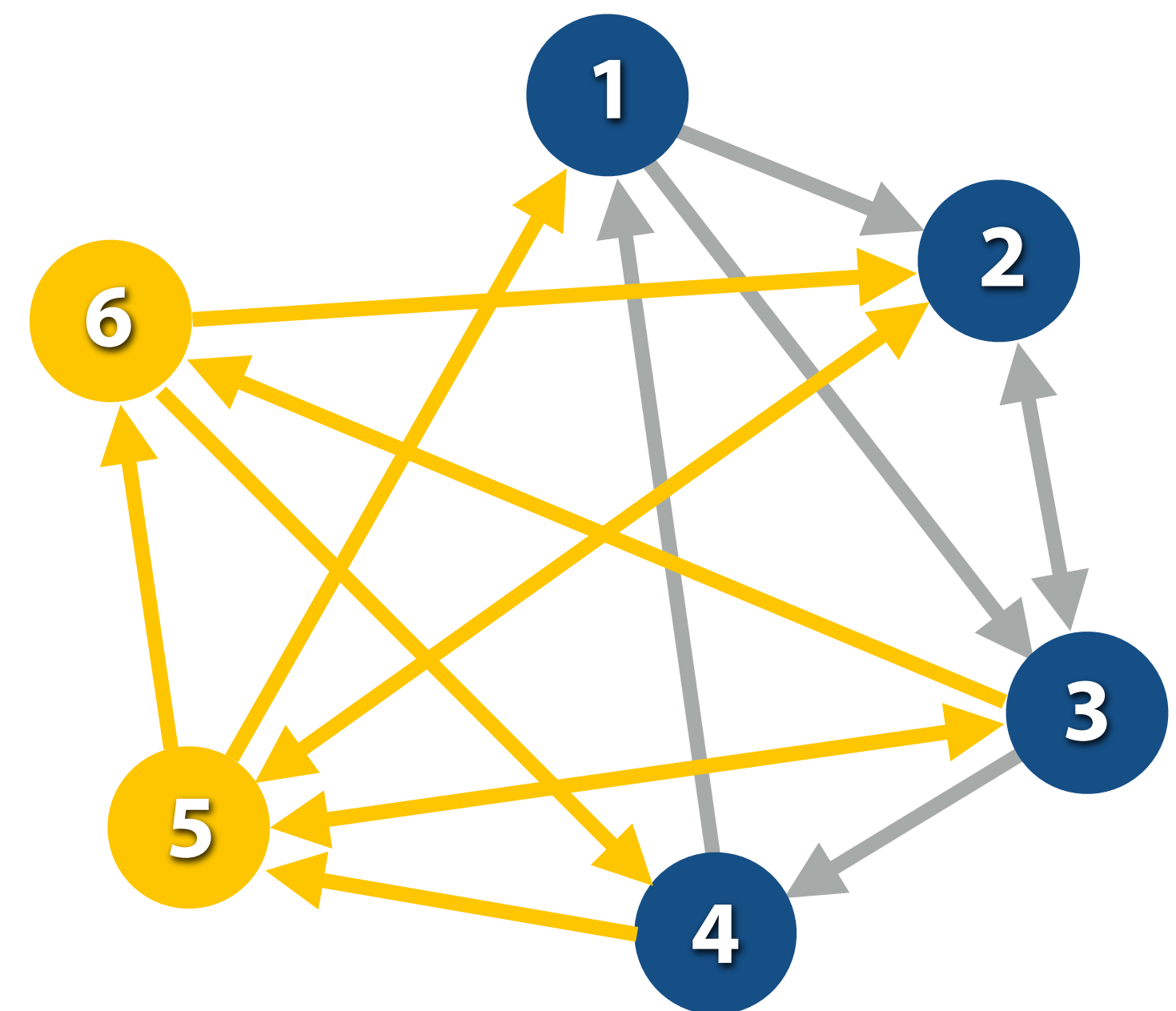

**Observe: due to sorting of incoming edges, iterating over all intervals results in contiguous sliding window over the shards**

# Putting it all together: looping over all graph edges

For each partition  $i$  of vertices:

- Load shard  $i$  (contains all incoming edges)
- For each other shard  $s$ 
  - Load section of  $s$  containing data for edges leaving  $i$  and entering  $s$
- Construct subgraph in memory
- Do processing on subgraph

**Note: a good implementation could hide disk I/O by prefetching data for next iteration of loop**

# Performance on a Mac mini (8 GB RAM)

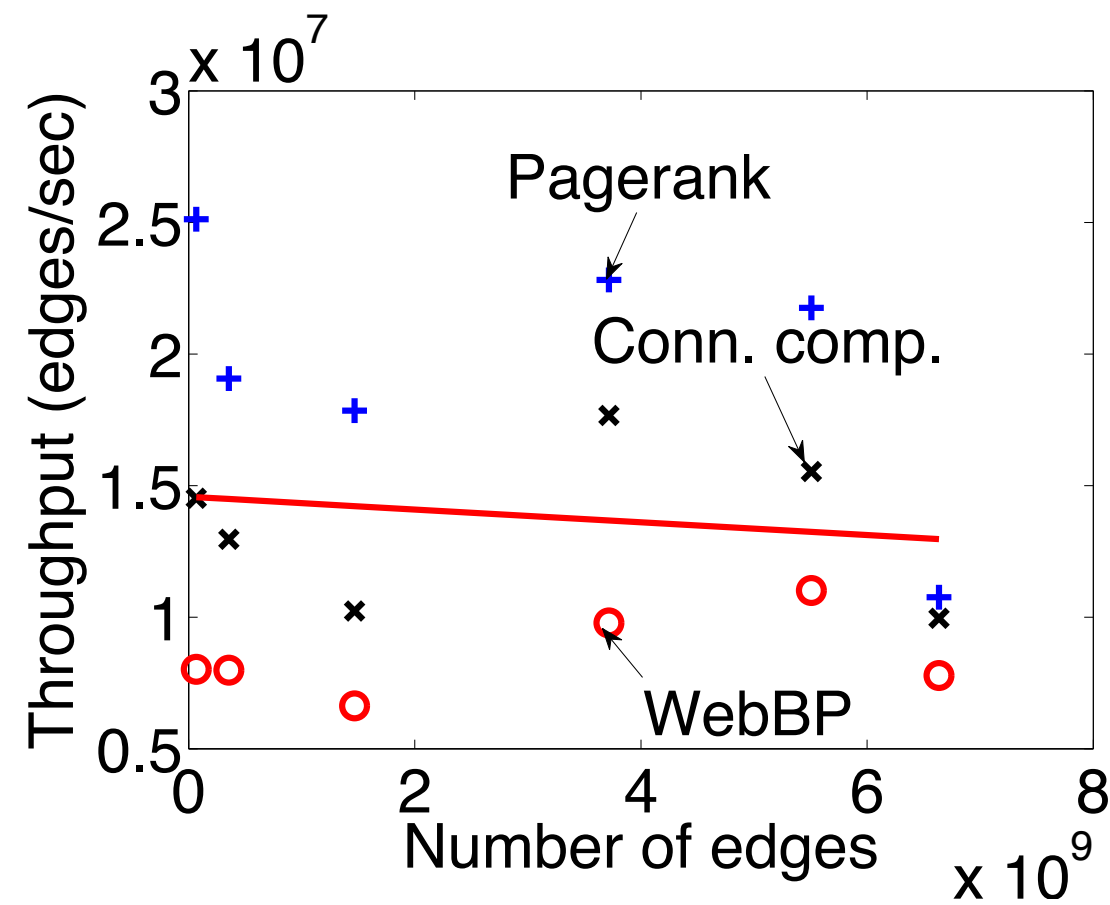

(a) Performance: SSD

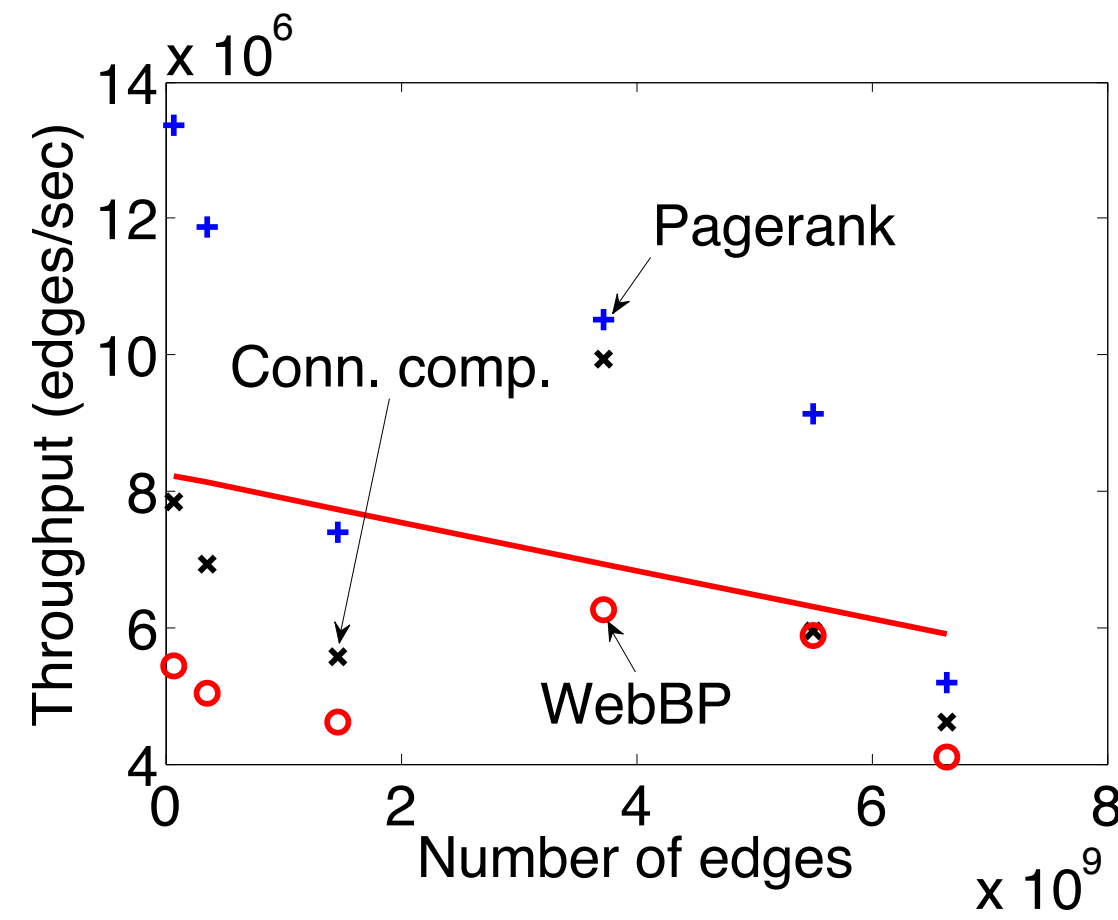

(b) Performance : Hard drive

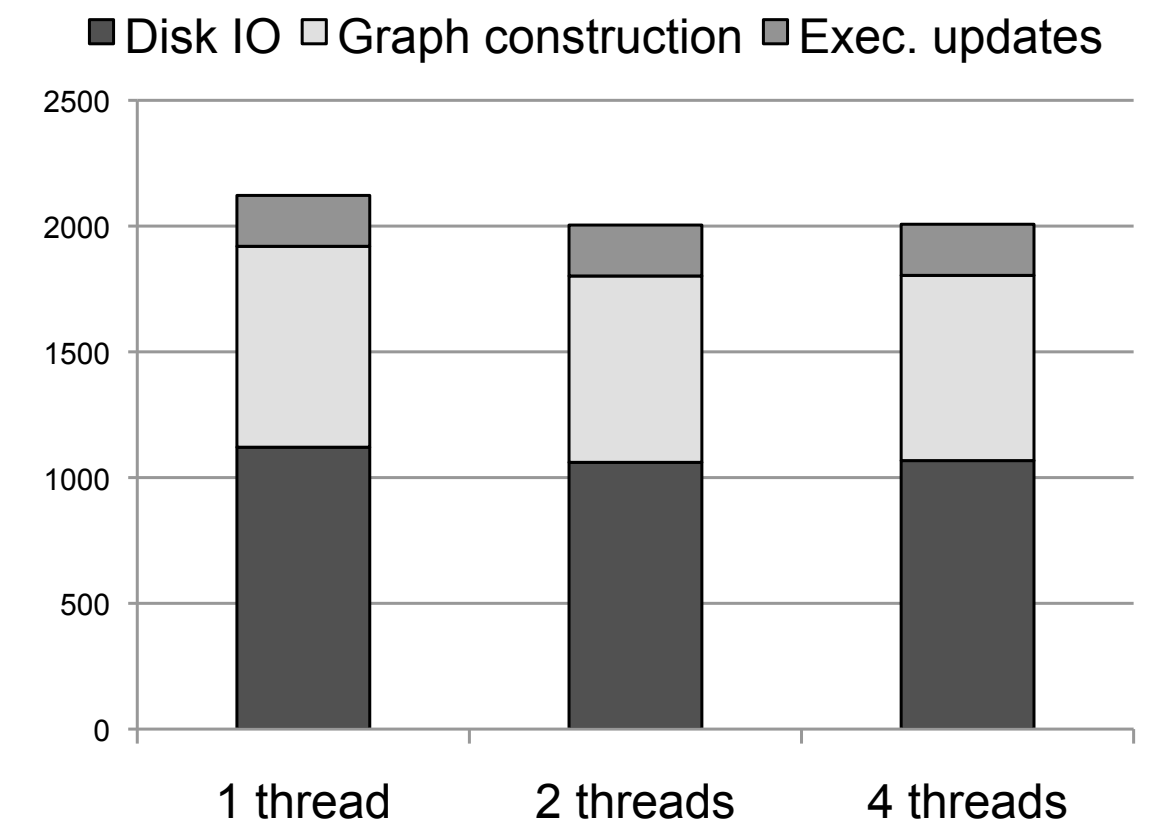

(c) Runtime breakdown

**Throughput (edges/sec) remains stable as graph size is increased**

- **Desirable property: throughput (edges/sec) largely invariant of dataset size**

# Graph compression

- **Recall: graph operations are often bandwidth bound**
- **Implication: using additional CPU instructions to reduce BW requirements can benefit overall performance (the processor would be waiting on memory anyway, so use it to decompress data!)**
- **Idea: store graph compressed in memory, decompress on-the-fly when operation wants to read data**

# Compressing an edge list

Vertex Id            32  
Outgoing Edges    1001 10 5 30 6 1025 200000 1010 1024 100000 1030 275000

---

## 1. Sort edges for each vertex

5 6 10 30 1001 1010 1024 1025 1030 100000 200000 275000

## 2. Compute differences

5 6 10 30 1001 1010 1024 1025 1030 100000 200000 275000  
0 1 4 20 971 9 14 1 5 98070 100000 75000

## 3. Group into sections requiring same number of bytes

relative to vertex index

5 6 10 30 1001 1010 1024 1025 1030 100000 200000 275000  
-27 1 4 20 971 9 14 1 5 98070 100000 75000

1 byte    2 bytes    1 byte    4 bytes

## 4. Encode deltas

Uncompressed encoding: 12 edges x 4 bytes = 48 bytes

Compressed encoding: 26 bytes

1-byte group header

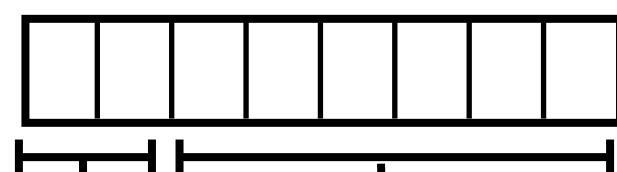

6 bits: number of edges in group

2 bits: encoding width (1, 2, 4 bytes)

[ONE\_BYTE, 4], -27, 1, 4, 20            (5 bytes)  
[TWO\_BYTE, 1], 971                        (3 bytes)  
[ONE\_BYTE, 4], 9, 14, 1, 5                (5 bytes)  
[FOUR\_BYTE, 3], 98070, 100000, 75000    (13 bytes)

# Performance impact of graph compression

[Shun et al. DDC 2015]

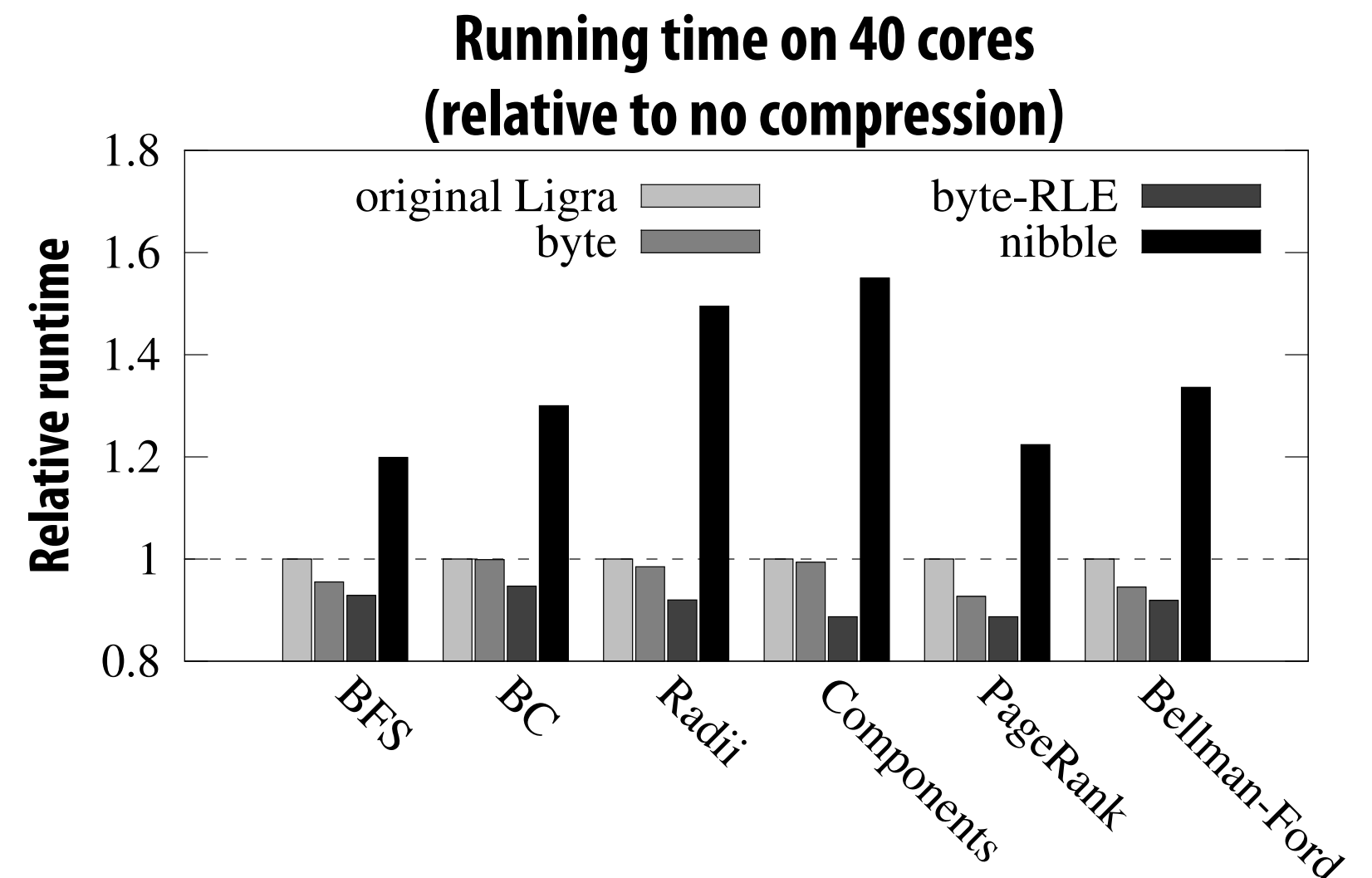
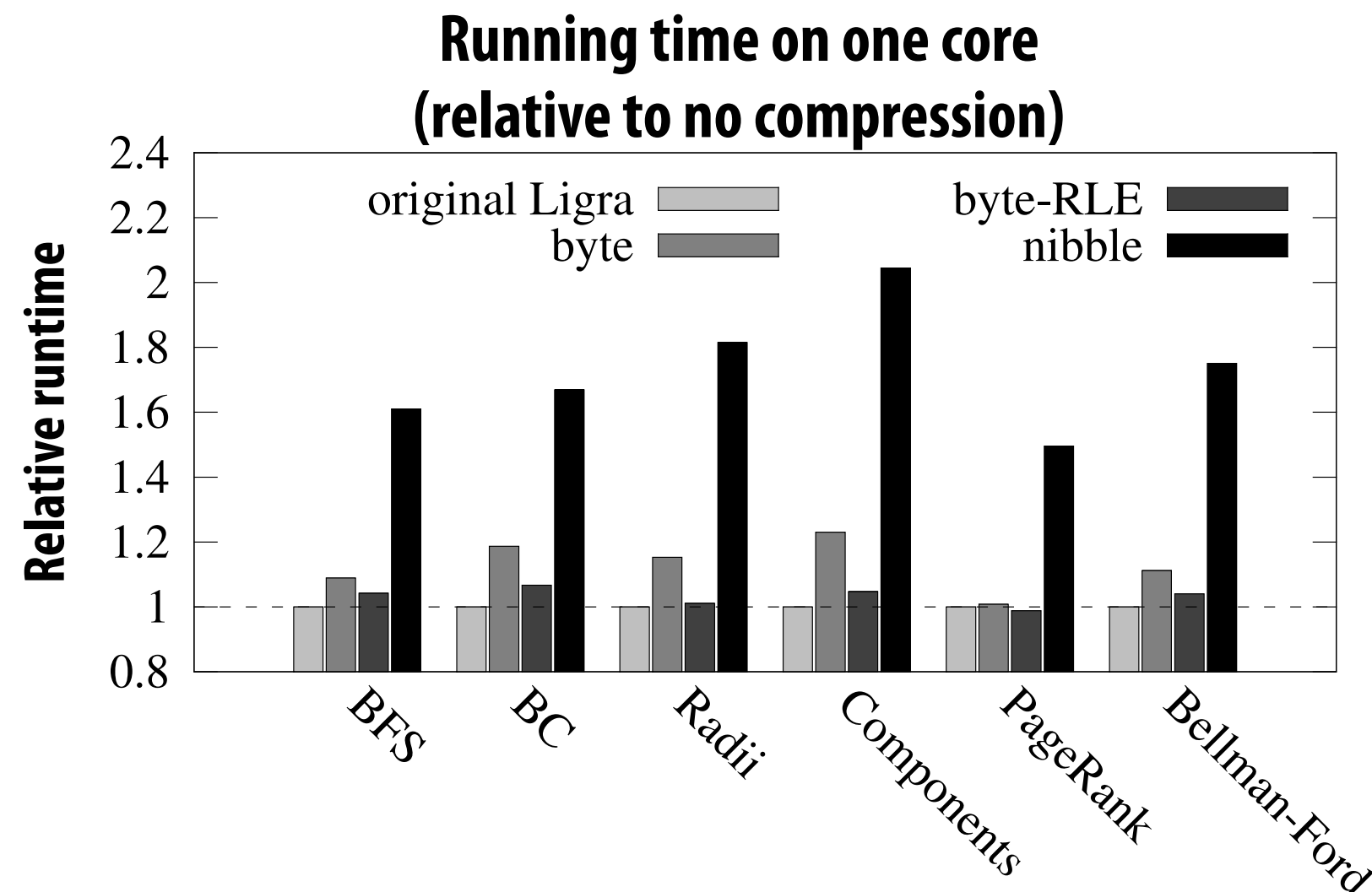

- **Benefit of graph compression increases with higher core count, since computation is increasingly bandwidth bound**
- **Performance improves even if graphs already fit in memory**
  - **Added benefit is that compression enables larger graphs to fit in memory**

\* Different data points on graphs are different compression schemes  
(byte-RLE is the scheme on the previous slide)



# Summary

- **Analyzing large graphs is a workload of high interest**
- **High performance execution requires**
  - **Parallelism (complexity emerges from need to synchronize updates to shared vertices or edges)**
  - **Locality optimizations (restructure graph for efficient I/O)**
  - **Graph compression (reduce amount memory BW or disk I/O)**
- **Graph-processing frameworks handle many of these details, while presenting the application programmer with domain-specific abstractions that make it easy to express graph analysis operations**

# How memory works

# Memory bandwidth limits

- **So far in this course, we've stressed the need for reducing bandwidth costs...**

# Well written programs exploit locality to avoid redundant data transfers between CPU and memory

(Key idea: place frequently accessed data in caches/buffers near processor)

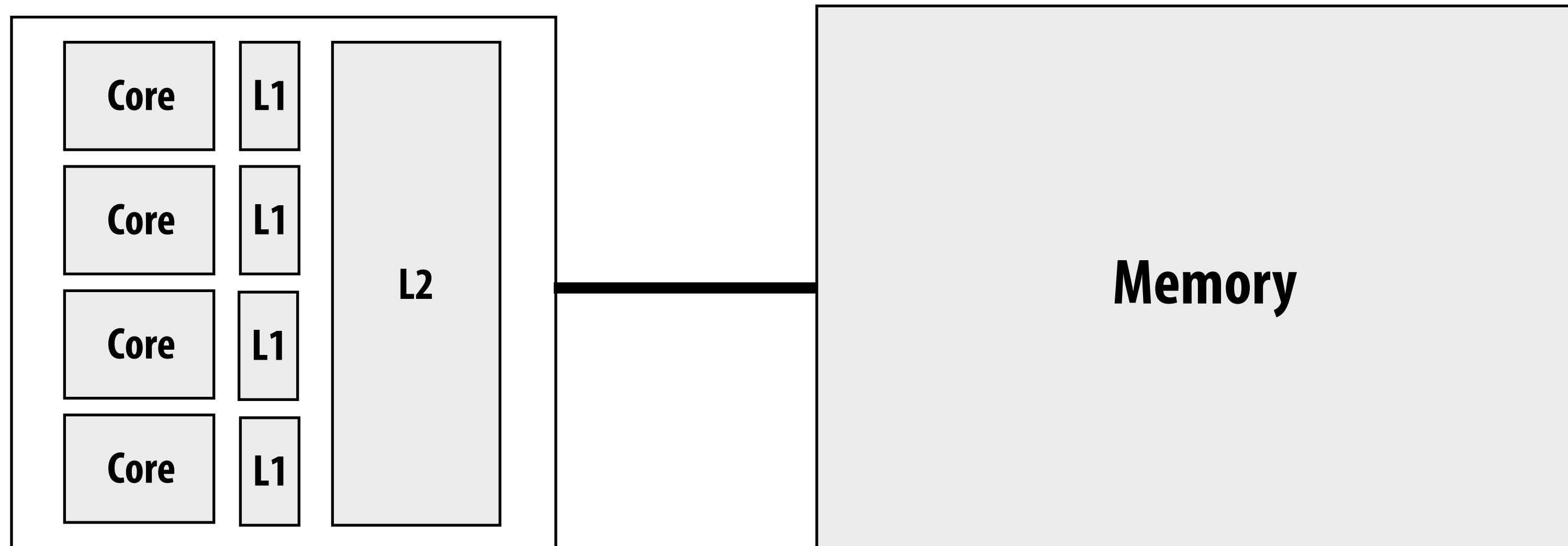

- Modern processors have high-bandwidth (and low latency) access to on-chip local storage
  - Computations featuring data access locality can reuse data in this storage
- Common software optimization technique: reorder computation so that cached data is accessed many times before it is evicted (“blocking”, “loop fusion”, etc.)
- Performance-aware programmers go to great effort to improve the cache locality of programs
  - What are good examples from this class?

# Example 1: restructuring loops for locality

## Program 1

```
void add(int n, float* A, float* B, float* C) {  
    for (int i=0; i<n; i++)  
        C[i] = A[i] + B[i];  
}
```

Two loads, one store per math op  
(arithmetic intensity = 1/3)

```
void mul(int n, float* A, float* B, float* C) {  
    for (int i=0; i<n; i++)  
        C[i] = A[i] * B[i];  
}
```

Two loads, one store per math op  
(arithmetic intensity = 1/3)

```
float* A, *B, *C, *D, *E, *tmp1, *tmp2;
```

```
// assume arrays are allocated here
```

```
// compute E = D + ((A + B) * C)
```

```
add(n, A, B, tmp1);
```

```
mul(n, tmp1, C, tmp2);
```

```
add(n, tmp2, D, E);
```

Overall arithmetic intensity = 1/3

## Program 2

```
void fused(int n, float* A, float* B, float* C, float* D, float* E) {  
    for (int i=0; i<n; i++)  
        E[i] = D[i] + (A[i] + B[i]) * C[i];  
}
```

Four loads, one store per 3 math ops  
(arithmetic intensity = 3/5)

```
// compute E = D + (A + B) * C
```

```
fused(n, A, B, C, D, E);
```

The transformation of the code in program 1 to the code in program 2 is called “loop fusion”

# Example 2: restructuring loops for locality

**Recall Apache Spark:**

**Programs are sequences of operations on collections (called RDDs)**

```
var lines = spark.textFile("hdfs://15418log.txt");
var lower = lines.map(_.toLowerCase());
var mobileViews = lower.filter(x => isMobileClient(x));
var howMany = mobileViews.count();
```

**Actual execution order of computation for the above lineage is similar to this...**

```
int count = 0;
while (inputFile.eof()) {
    string line = inputFile.readLine();
    string lower = line.toLowerCase();
    if (isMobileClient(lower))
        count++;
}
```

# Example 3: restructuring loops for locality

## Program 1

```

int WIDTH = 1024;
int HEIGHT = 1024;
float input[(WIDTH+2) * (HEIGHT+2)];
float tmp_buf[WIDTH * (HEIGHT+2)];
float output[WIDTH * HEIGHT];

float weights[] = {1.0/3, 1.0/3, 1.0/3};

// blur image horizontally
for (int j=0; j<(HEIGHT+2); j++)
  for (int i=0; i<WIDTH; i++) {
    float tmp = 0.f;
    for (int ii=0; ii<3; ii++)
      tmp += input[j*(WIDTH+2) + i+ii] * weights[ii];
    tmp_buf[j*WIDTH + i] = tmp;
  }

// blur tmp_buf vertically
for (int j=0; j<HEIGHT; j++) {
  for (int i=0; i<WIDTH; i++) {
    float tmp = 0.f;
    for (int jj=0; jj<3; jj++)
      tmp += tmp_buf[(j+jj)*WIDTH + i] * weights[jj];
    output[j*WIDTH + i] = tmp;
  }
}

```

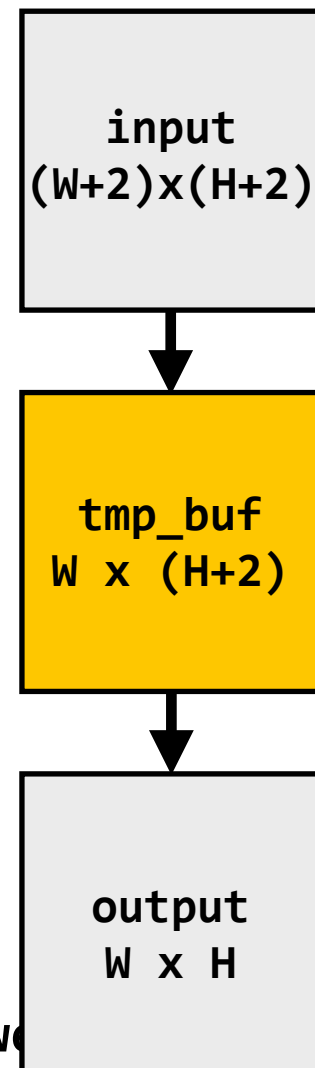

## Program 2

```

int WIDTH = 1024;
int HEIGHT = 1024;
float input[(WIDTH+2) * (HEIGHT+2)];
float tmp_buf[WIDTH * (CHUNK_SIZE+2)];
float output[WIDTH * HEIGHT];

float weights[] = {1.0/3, 1.0/3, 1.0/3};

for (int j=0; j<HEIGHT; j+CHUNK_SIZE) {

  // blur region of image horizontally
  for (int j2=0; j2<CHUNK_SIZE+2; j2++)
    for (int i=0; i<WIDTH; i++) {
      float tmp = 0.f;
      for (int ii=0; ii<3; ii++)
        tmp += input[(j+j2)*(WIDTH+2) + i+ii] * weights[ii];
      tmp_buf[j2*WIDTH + i] = tmp;
    }

  // blur tmp_buf vertically
  for (int j2=0; j2<CHUNK_SIZE; j2++)
    for (int i=0; i<WIDTH; i++) {
      float tmp = 0.f;
      for (int jj=0; jj<3; jj++)
        tmp += tmp_buf[(j2+jj)*WIDTH + i] * weights[jj];
      output[(j+j2)*WIDTH + i] = tmp;
    }
}

```

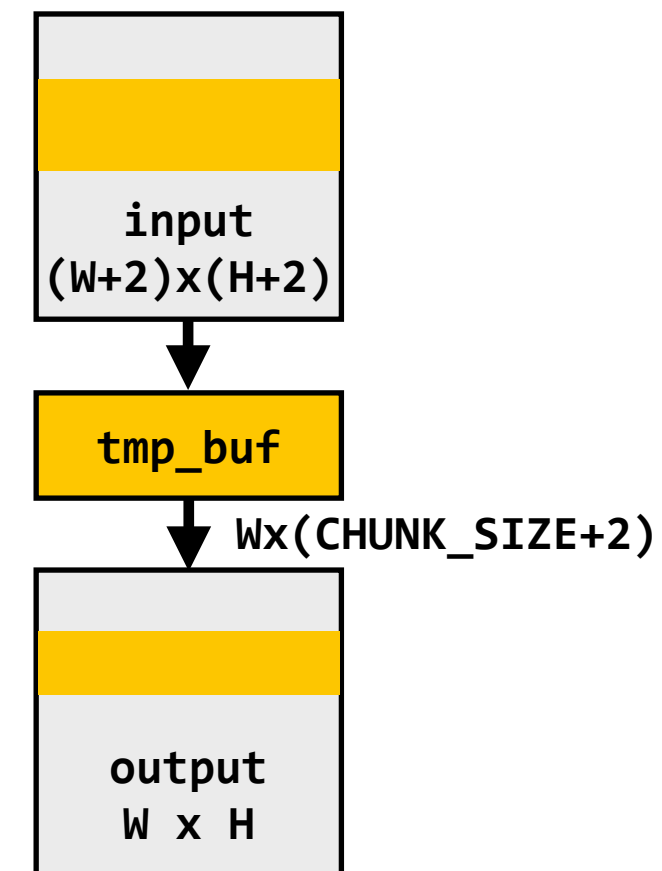

# Data movement has high energy cost

- **Rule of thumb in mobile system design: always seek to reduce amount of data transferred from memory**
  - **Earlier in class we discussed minimizing communication to reduce stalls (poor performance). Now, we wish to reduce communication to reduce energy consumption**
- **“Ballpark” numbers** [Sources: Bill Dally (NVIDIA), Tom Olson (ARM)]
  - Integer op: ~ 1 pJ \*
  - Floating point op: ~20 pJ \*
  - Reading 64 bits from small local SRAM (1mm away on chip): ~ 26 pJ
  - Reading 64 bits from low power mobile DRAM (LPDDR): ~1200 pJ ← **Suggests that recomputing values, rather than storing and reloading them, is a better answer when optimizing code for energy efficiency!**
- **Implications**
  - Reading 10 GB/sec from memory: ~1.6 watts
  - Entire power budget for mobile GPU: ~1 watt (remember phone is also running CPU, display, radios, etc.)
  - iPhone 11 battery: ~12 watt-hours (note: my Macbook Pro laptop: 99 watt-hour battery)
  - Exploiting locality matters!!!



# Moving data is costly!

## Data movement limits performance

Many processing elements...

= higher overall rate of memory requests

= need for more memory bandwidth

(result: bandwidth-limited execution)

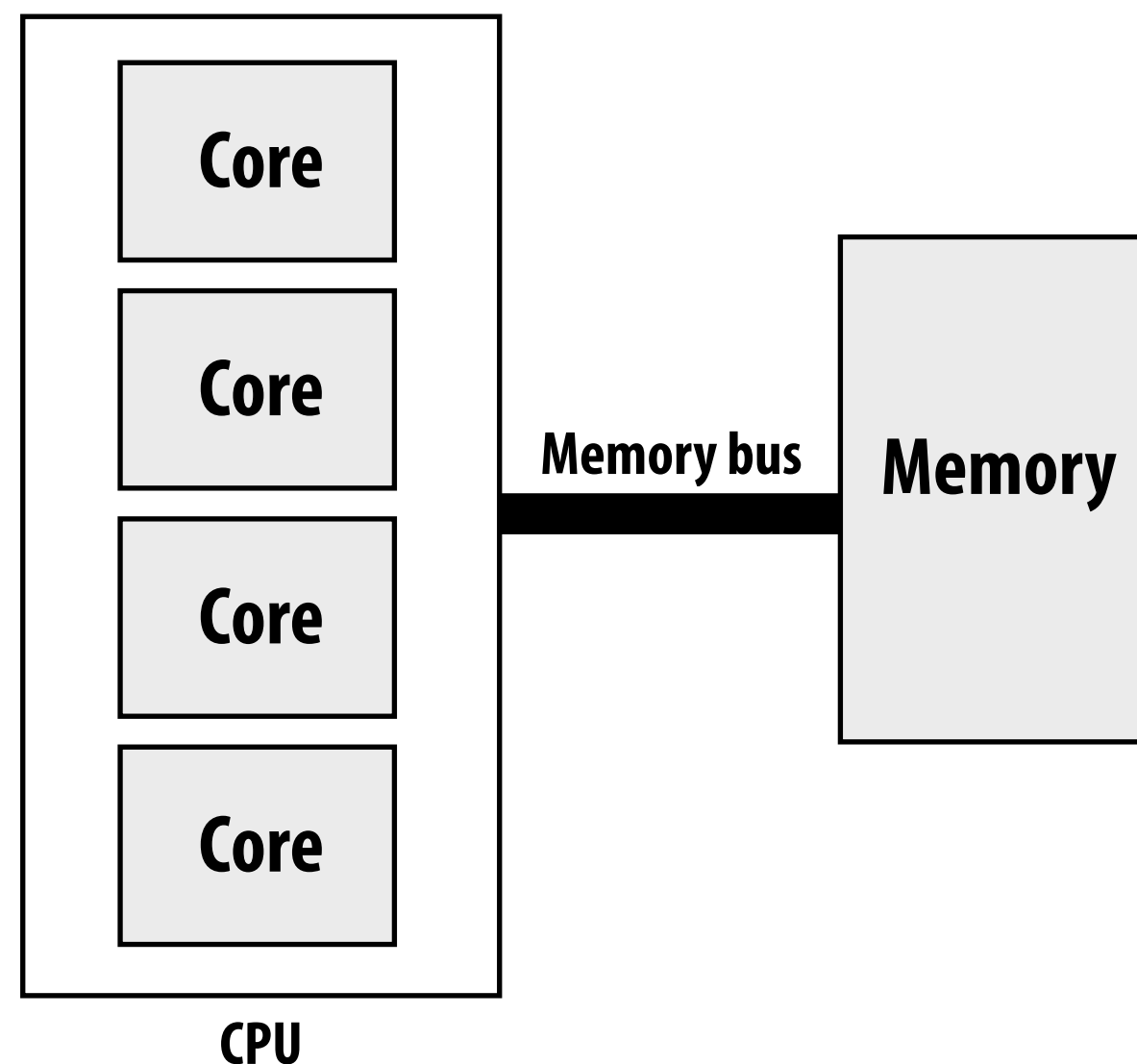

## Data movement has high energy cost

~ 0.9 pJ for a 32-bit floating-point math op \*

~ 5 pJ for a local SRAM (on chip) data access

~ 640 pJ to load 32 bits from LPDDR memory

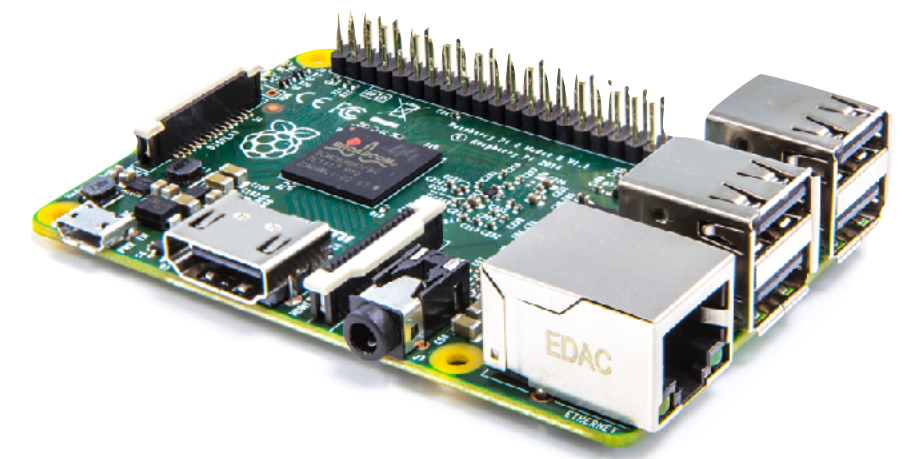

\* Source: [Han, ICLR 2016], 45 nm CMOS assumption

# **Accessing DRAM**

**(a basic tutorial on how DRAM works)**

# The memory system

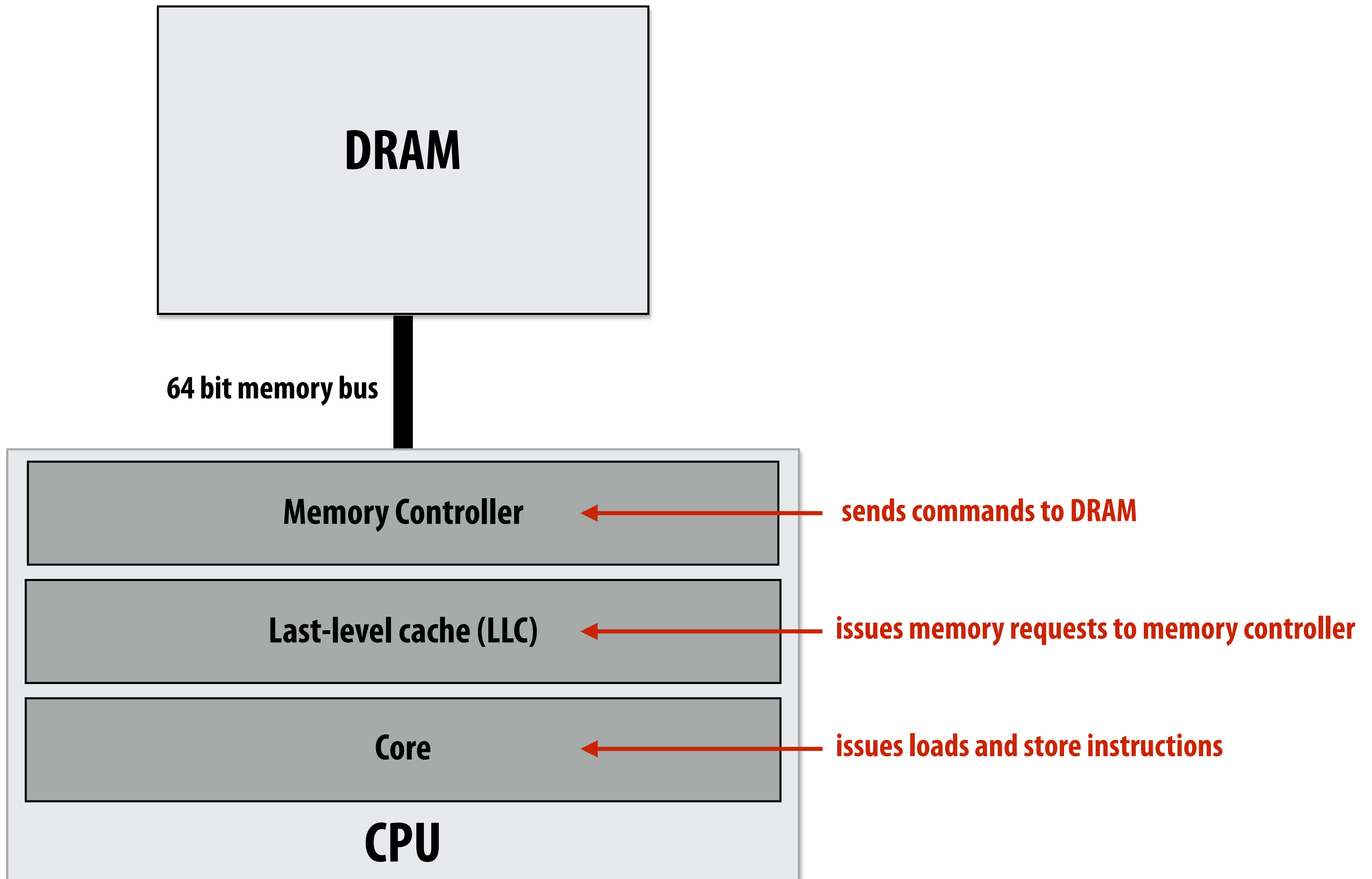

# DRAM array

1 transistor + capacitor per "bit"

(Recall: a capacitor stores charge)

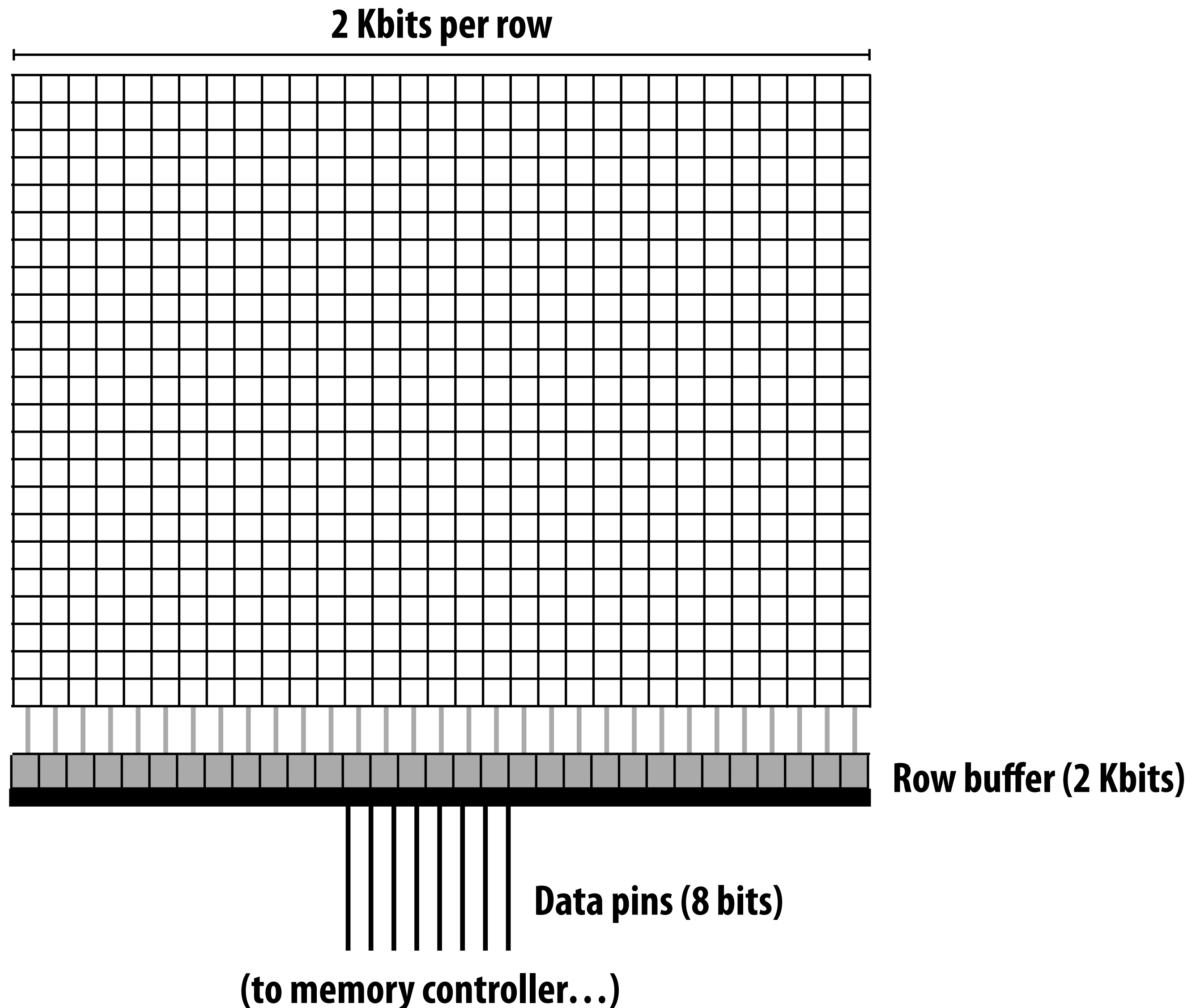

# DRAM operation (load one byte)

Estimated latencies are in units of memory clocks:  
DDR3-1600 (Kayvon's laptop)

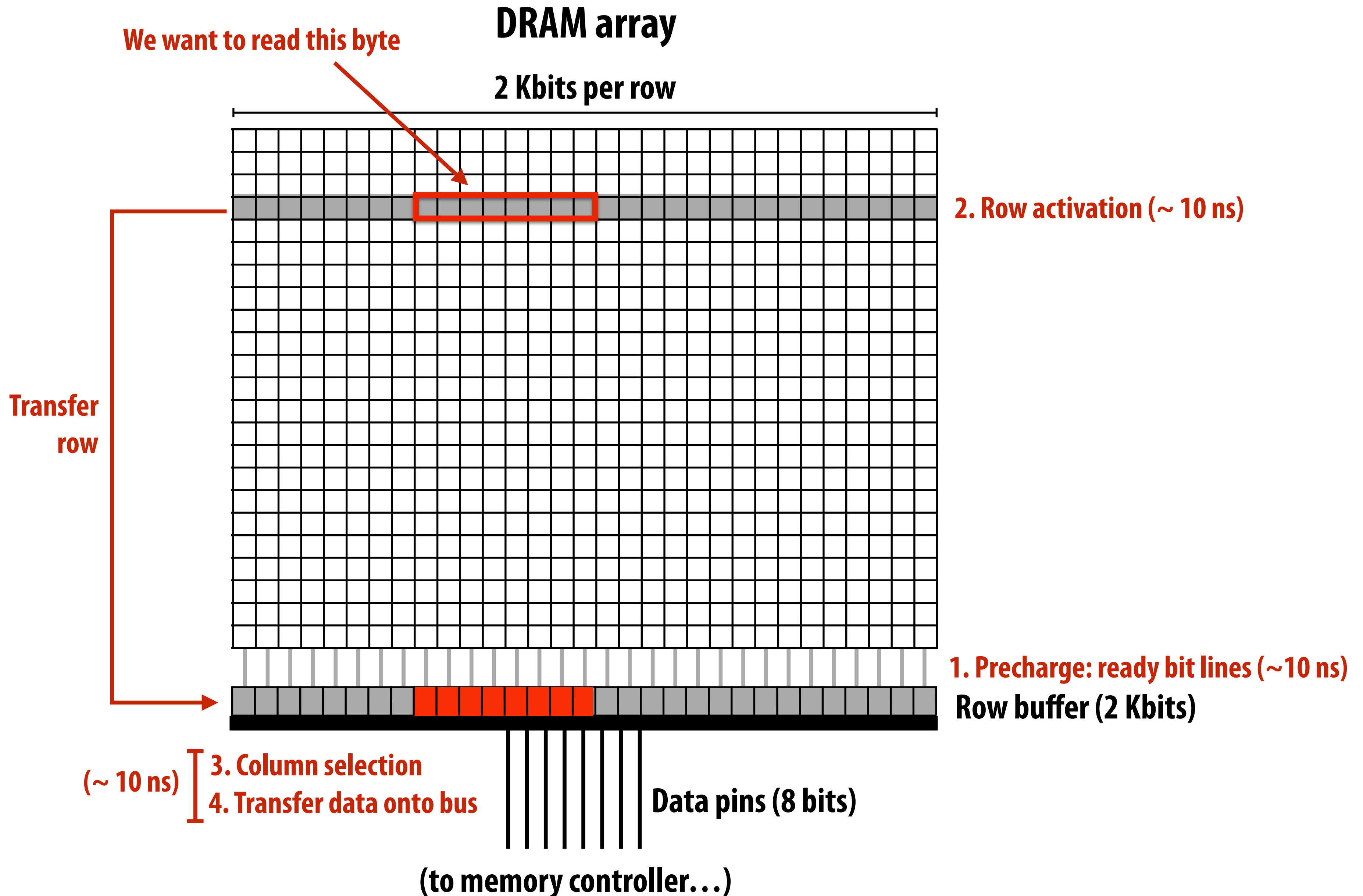

# Load next byte from (already active) row

Lower latency operation: can skip precharge and row activation steps

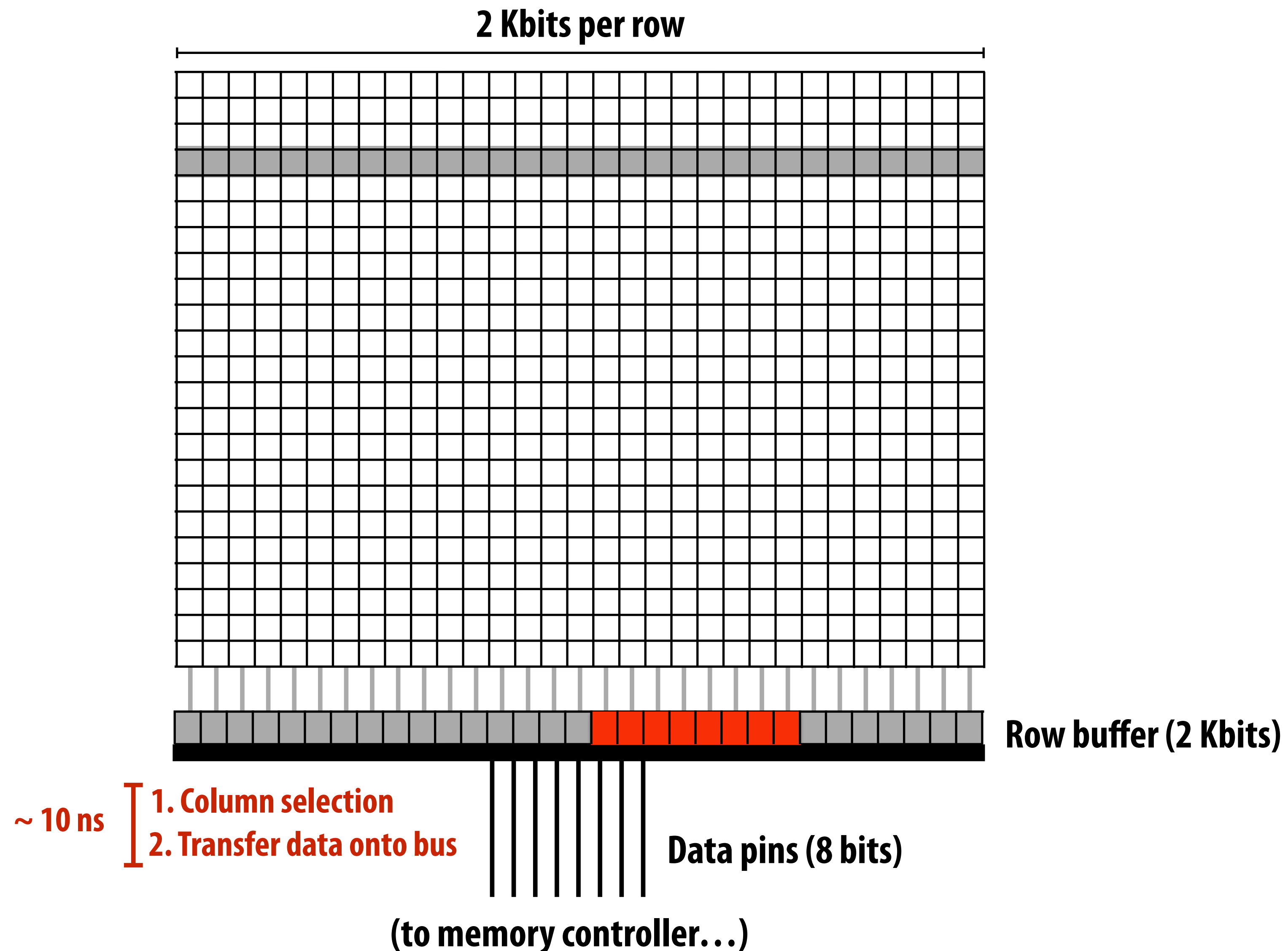

# DRAM access latency is not fixed

- **Best case latency: read from active row**
  - Column access time (CAS)
- **Worst case latency: bit lines not ready, read from new row**
  - Precharge (PRE) + row activate (RAS) + column access (CAS)

← Precharge readies bit lines and writes row buffer contents back into DRAM array (read was destructive)
- **Question 1: when to execute precharge?**
  - After each column access?
  - Only when new row is accessed?
- **Question 2: how to handle latency of DRAM access?**

# Problem: low pin utilization due to latency of access

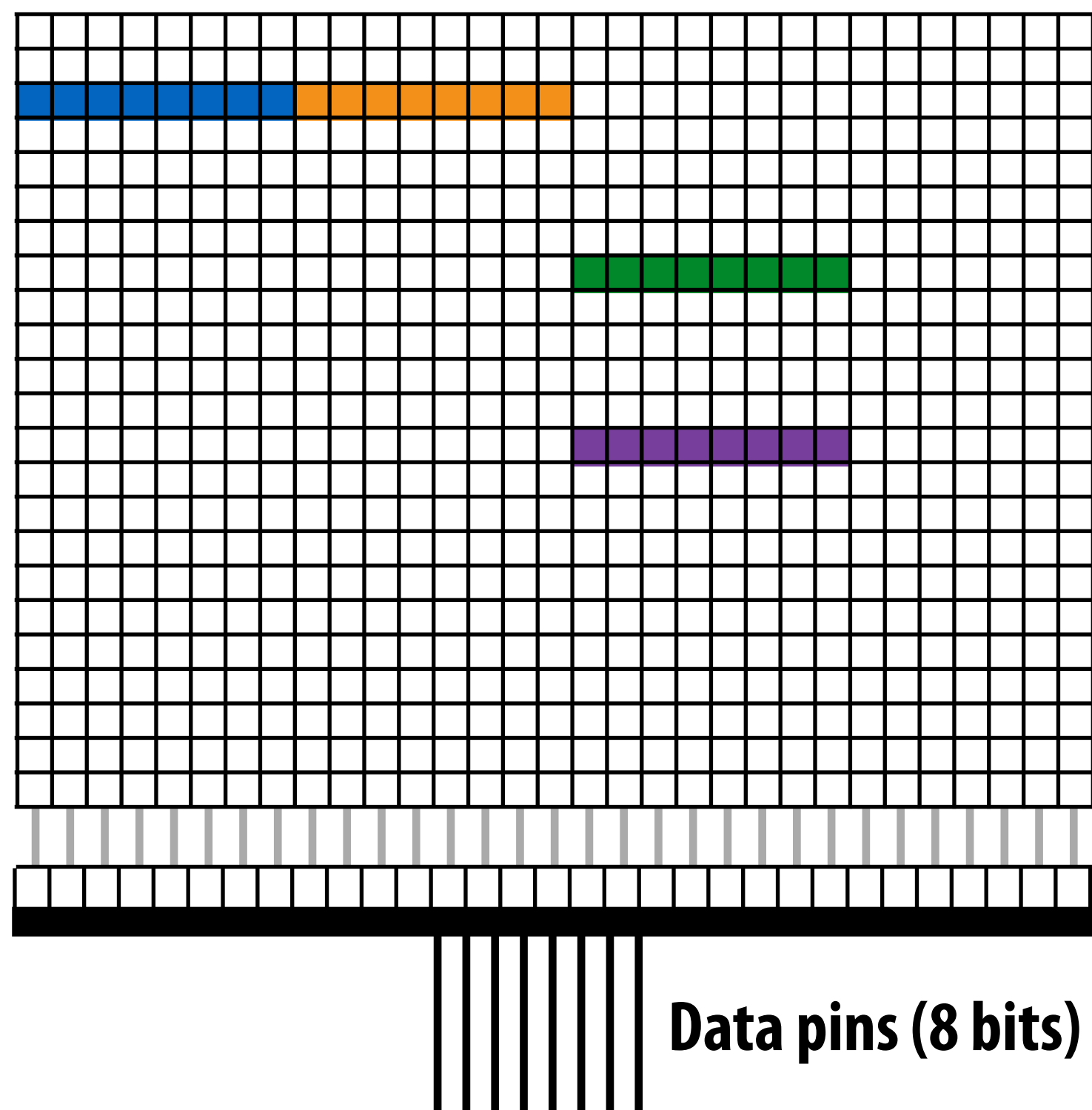
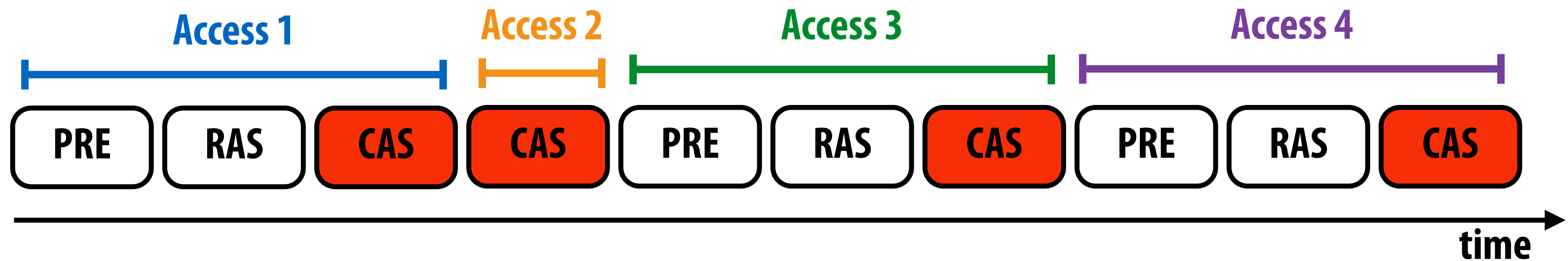

**Data pins in use only a small fraction of time  
(red = data pins busy)**

**This is bad since they are the scarcest resource!**



# DRAM burst mode

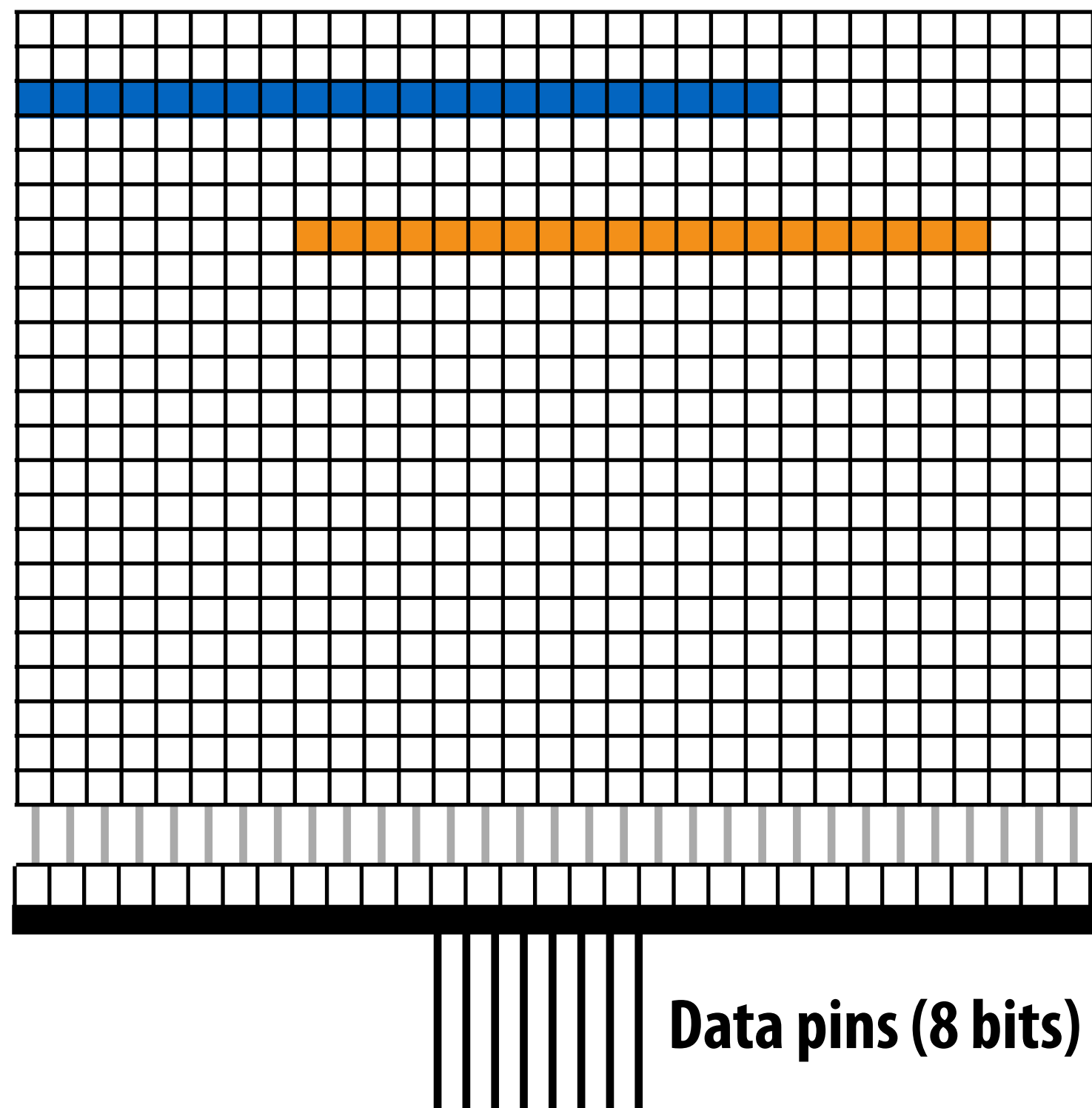
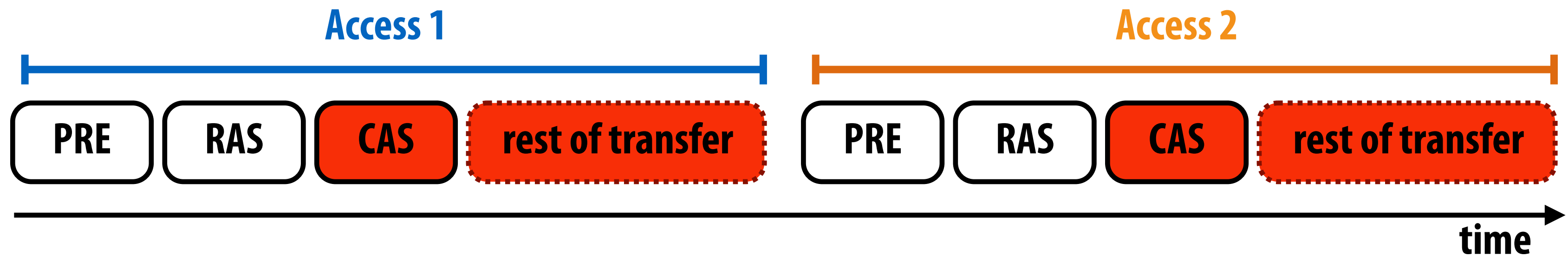

**Idea: amortize latency over larger transfers**

**Each DRAM command describes bulk transfer**  
**Bits placed on output pins in consecutive clocks**

# DRAM chip consists of multiple banks

- All banks share same pins (only one transfer at a time)
- Banks allow for pipelining of memory requests
  - Precharge/activate rows/send column address to one bank while transferring data from another
  - Achieves high data pin utilization

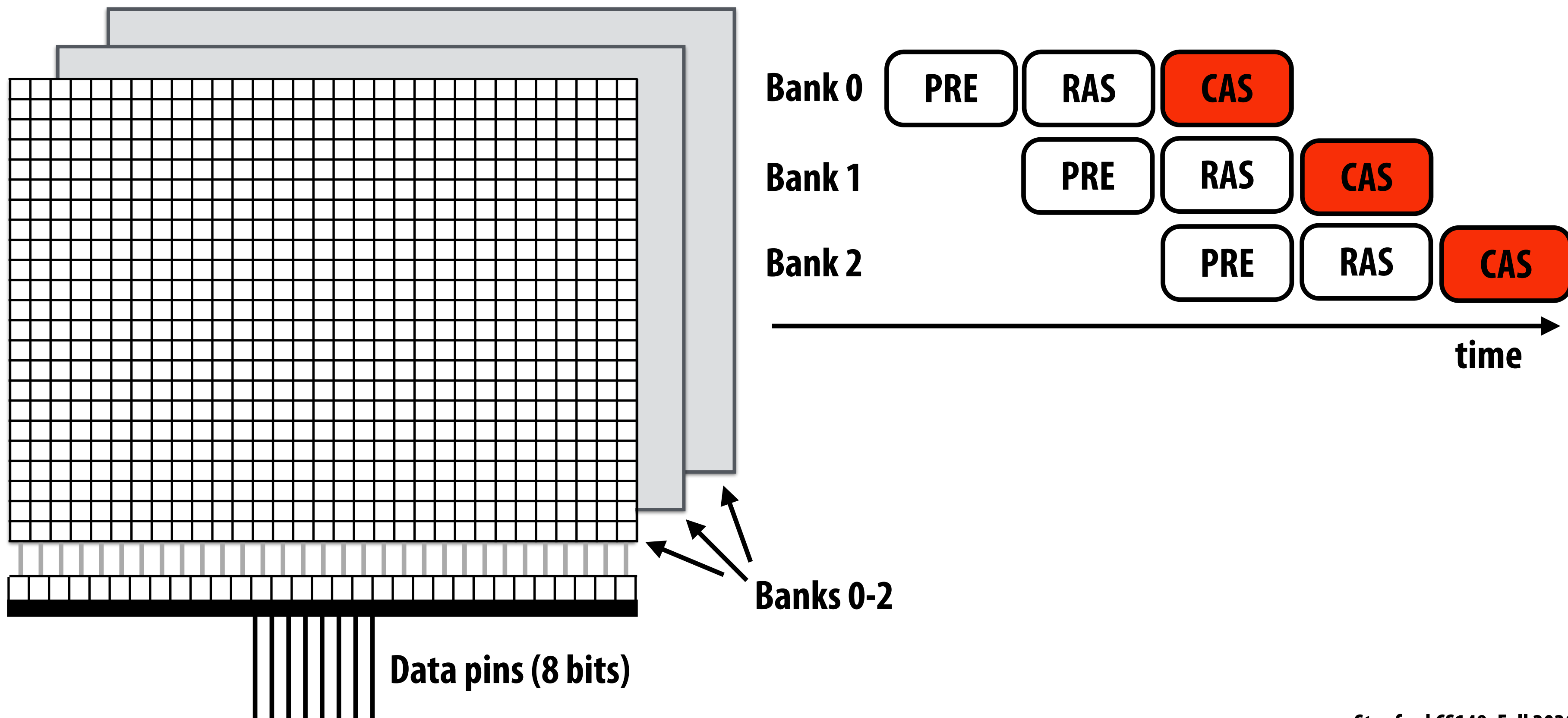

# Organize multiple chips into a DIMM

Example: Eight DRAM chips (64-bit memory bus)

Note: DIMM appears as a single, higher capacity, wider interface DRAM module to the memory controller. Higher aggregate bandwidth, but minimum transfer granularity is now 64 bits.

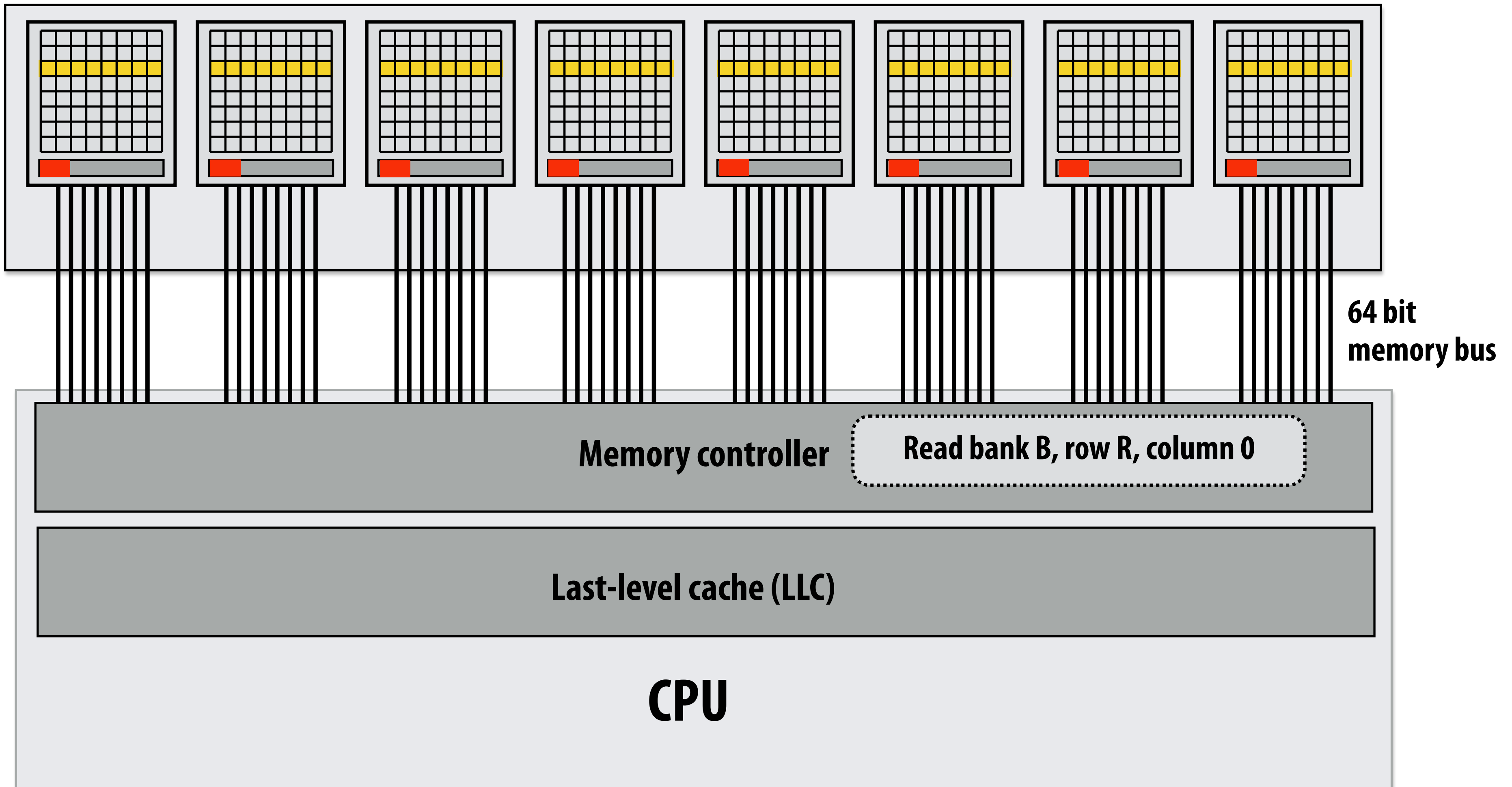

# Reading one 64-byte (512 bit) cache line (the wrong way)

Assume: consecutive physical addresses mapped to same row of same chip  
Memory controller converts physical address to DRAM bank, row, column

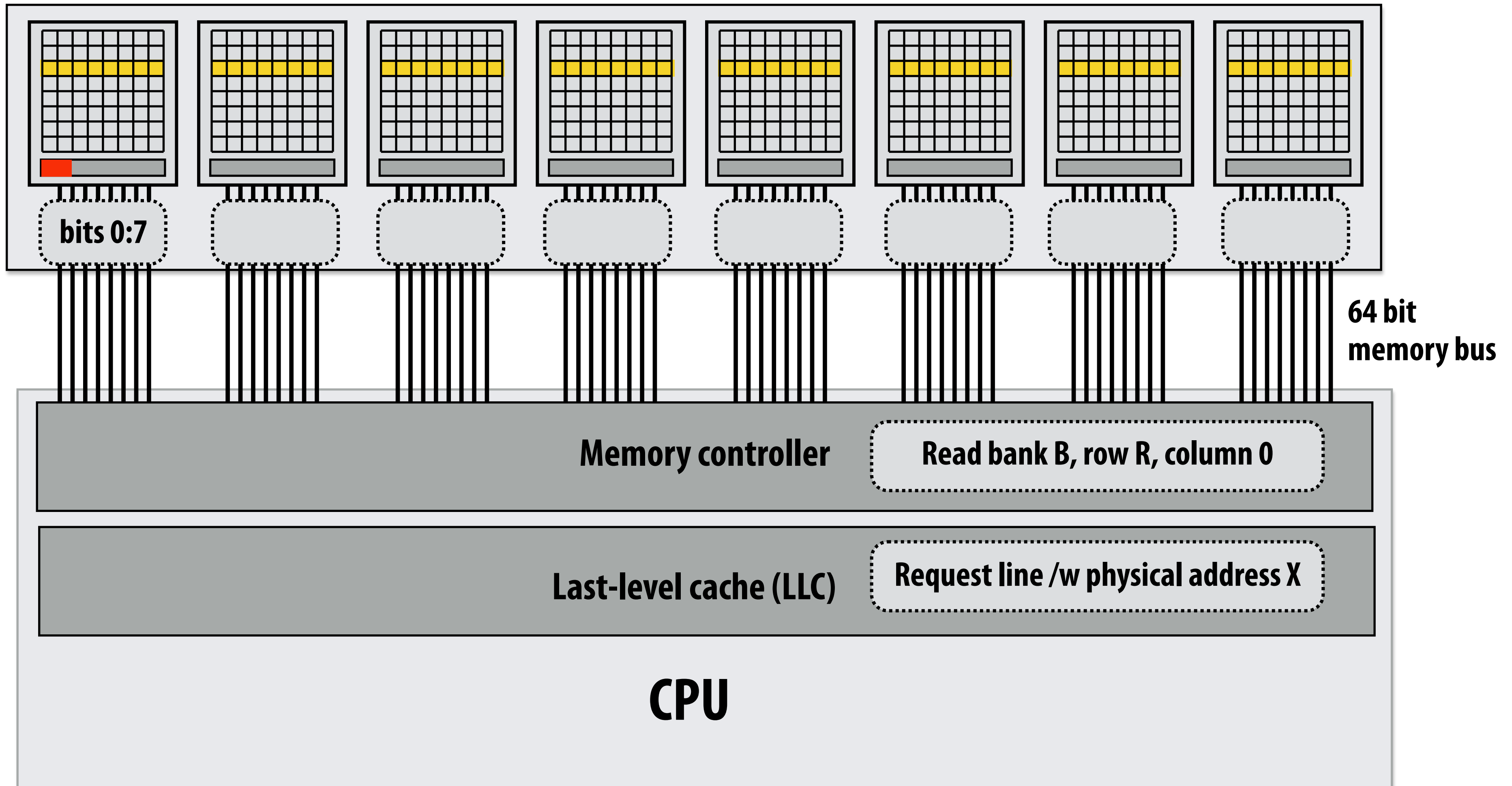

# Reading one 64-byte (512 bit) cache line (the wrong way)

All data for cache line serviced by the same chip  
Bytes sent consecutively over same pins

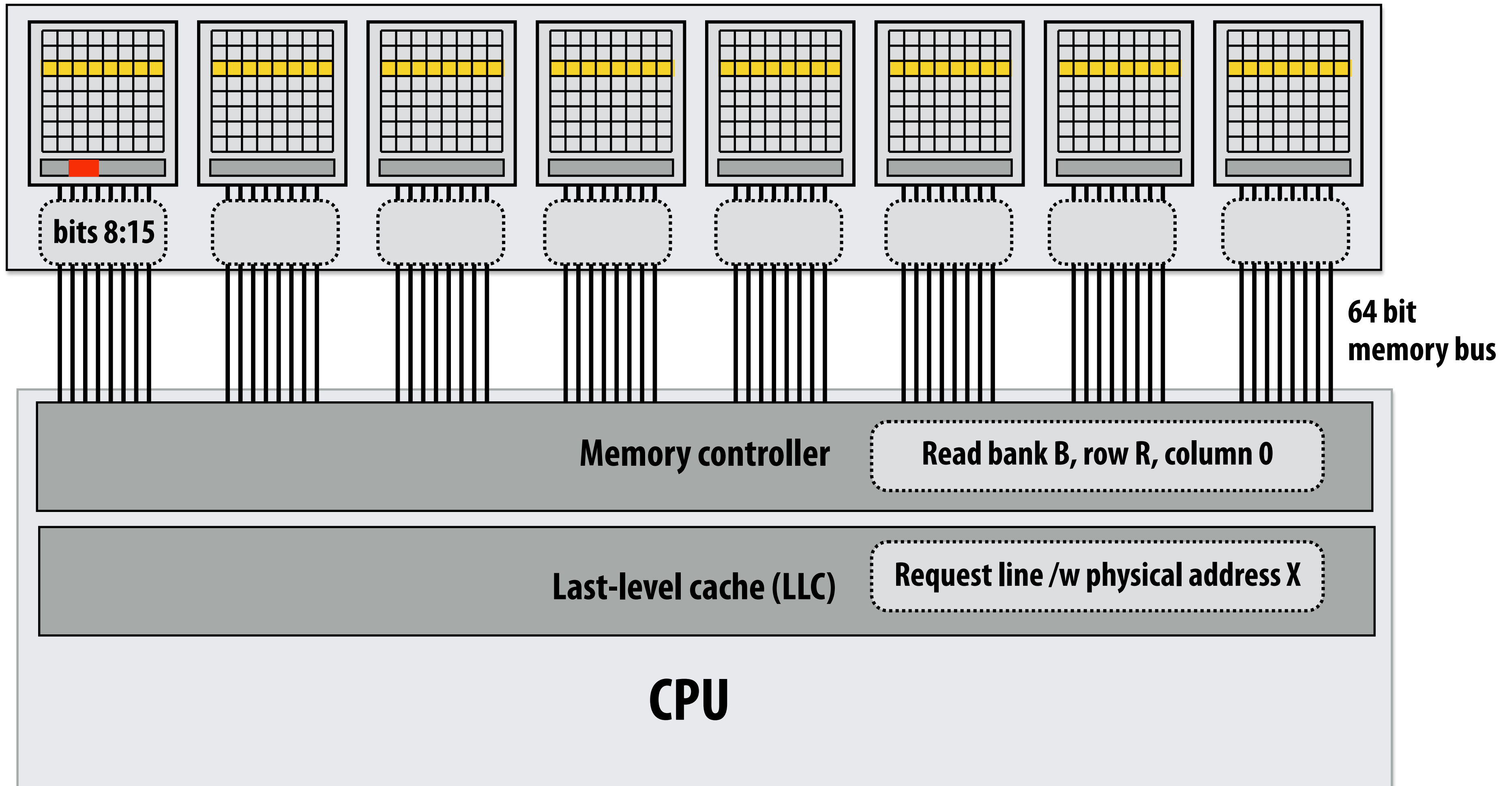

# Reading one 64-byte (512 bit) cache line (the wrong way)

All data for cache line serviced by the same chip  
Bytes sent consecutively over same pins

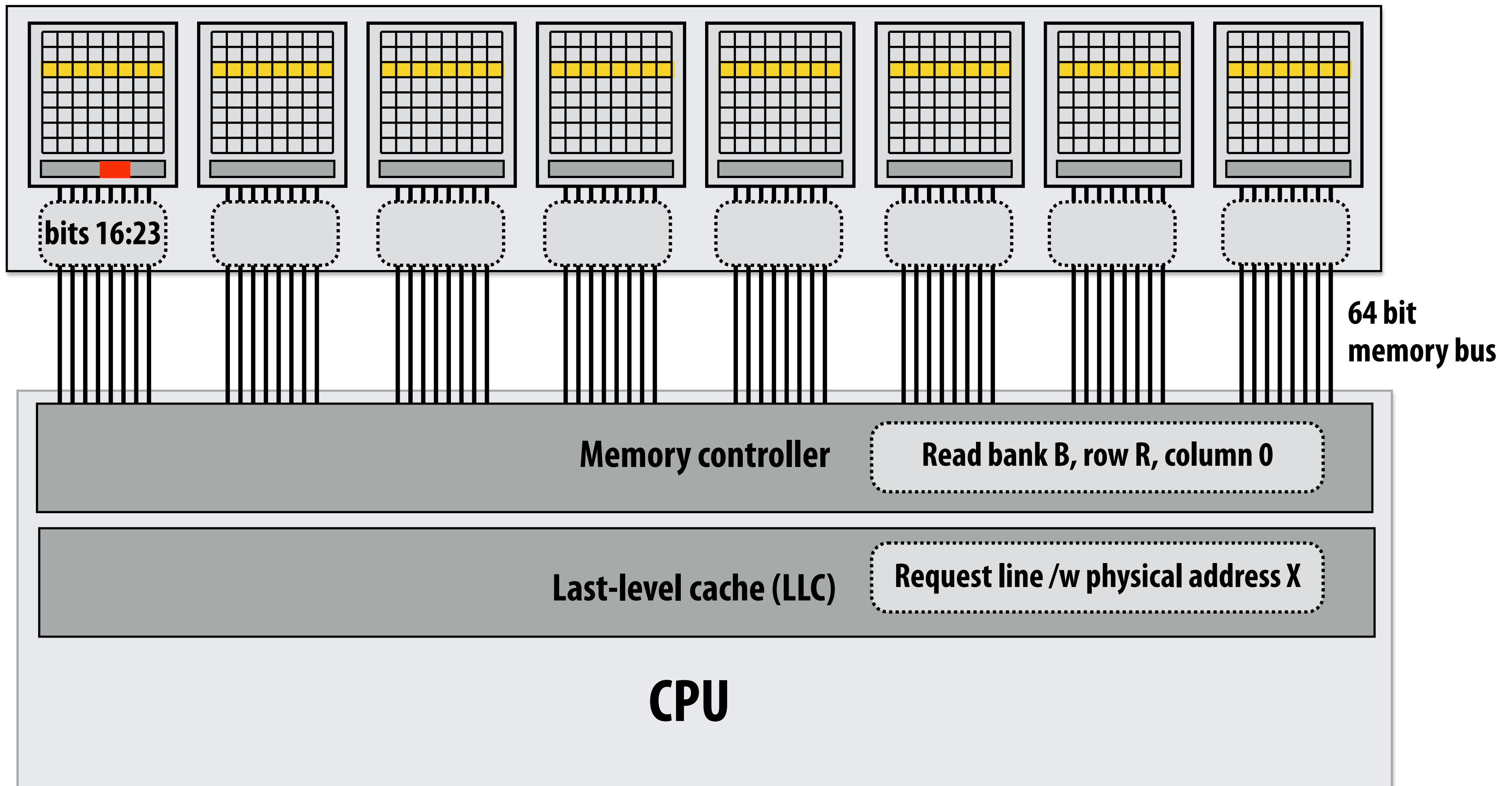

# Reading one 64-byte (512 bit) cache line

Memory controller converts physical address to DRAM bank, row, column

Here: physical addresses are interleaved across DRAM chips at byte granularity

DRAM chips transmit first 64 bits in parallel

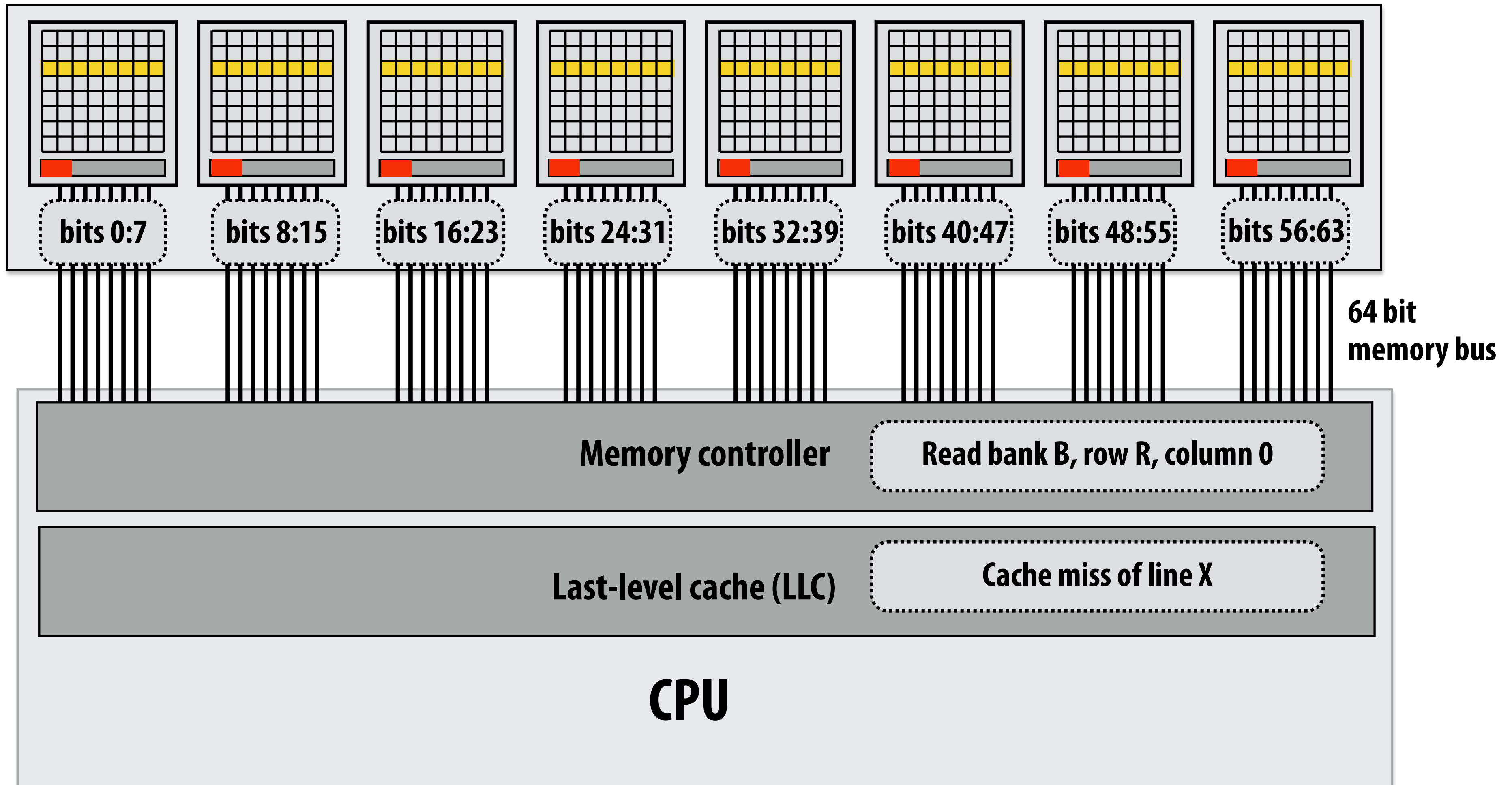

# Reading one 64-byte (512 bit) cache line

DRAM controller requests data from new column \*

DRAM chips transmit next 64 bits in parallel

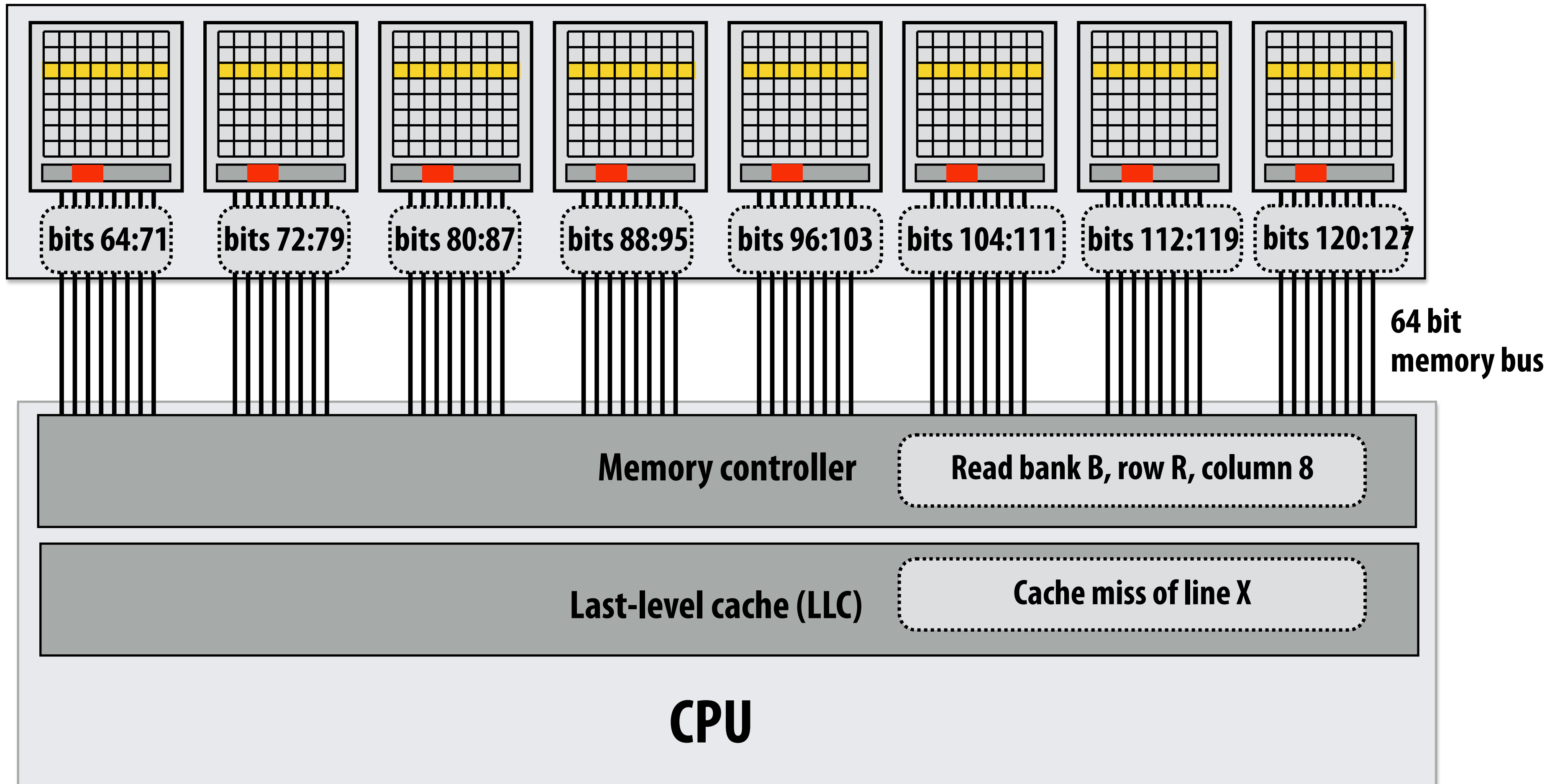

\* Recall modern DRAM's support burst mode transfer of multiple consecutive columns, which would be used here



# Memory controller is a memory request scheduler

- **Receives load/store requests from LLC**
- **Conflicting scheduling goals**
  - Maximize throughput, minimize latency, minimize energy consumption
  - Common scheduling policy: FR-FCFS (first-ready, first-come-first-serve)
    - Service requests to currently open row first (maximize row locality)
    - Service requests to other rows in FIFO order
  - Controller may coalesce multiple small requests into large contiguous requests (to take advantage of DRAM “burst modes”)

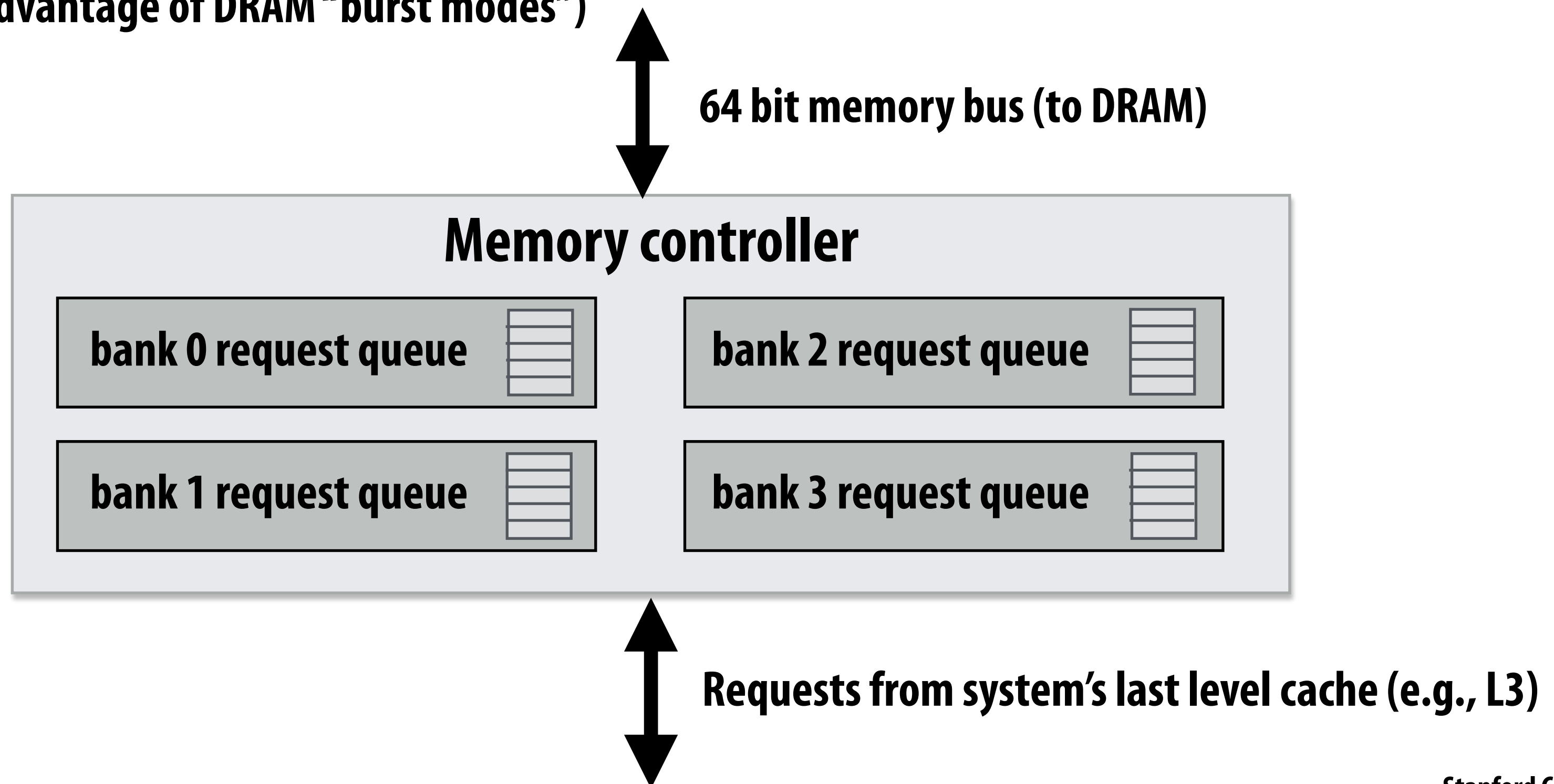

# Dual-channel memory system

- Increase throughput by adding memory channels (effectively widen bus)
- Below: each channel can issue independent commands
  - Different row/column is read in each channel
  - Simpler setup: use single controller to drive same command to multiple channels

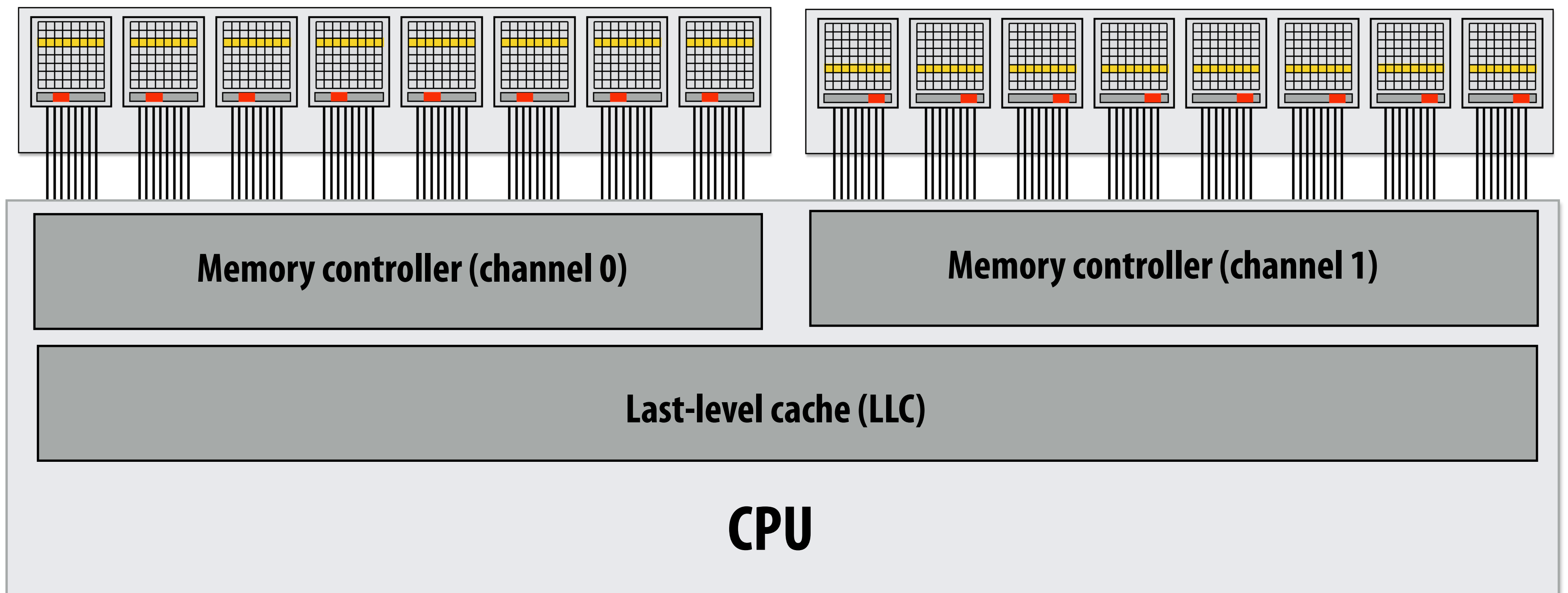



# Example: DDR4 memory

**Processor: Intel® Core™ i7-7700K Processor (in Myth cluster)**

**Memory system details from Intel's site:**

<https://ark.intel.com/content/www/us/en/ark/products/97129/intel-core-i7-7700k-processor-8m-cache-up-to-4-50-ghz.html>

## Memory Specifications

Max Memory Size (dependent on memory type) 	64 GB
Memory Types 	DDR4-2133/2400, DDR3L-1333/1600 @ 1.35V
Max # of Memory Channels 	2
ECC Memory Supported † 	No

## DDR4 2400

- **64-bit memory bus x 1.2GHz x 2 transfers per clock\* = 19.2GB/s per channel**
- **2 channels = 38.4 GB/sec**
- **~13 nanosecond CAS**

**\* DDR stands for “double data rate”**

# DRAM summary

- **DRAM access latency can depend on many low-level factors**
  - **Discussed today:**
    - **State of DRAM chip: row hit/miss? is recharge necessary?**
    - **Buffering/reordering of requests in memory controller**
- **Significant amount of complexity in a modern multi-core processor has moved into the design of memory controller**
  - **Responsible for scheduling ten's to hundreds of outstanding memory requests**
  - **Responsible for mapping physical addresses to the geometry of DRAMs**
  - **Area of active computer architecture research**

**Modern architecture challenge:  
improving memory performance:**

**Decrease distance data must move by  
locating memory closer to processors**

**(enables shorter, but wider interfaces)**



# GPUs are adopting HBM technologies

## AMD Radeon Fury GPU (2015)

4096-bit interface: 4 HBM chips x 1024 bit interface per chip  
512 GB/sec BW

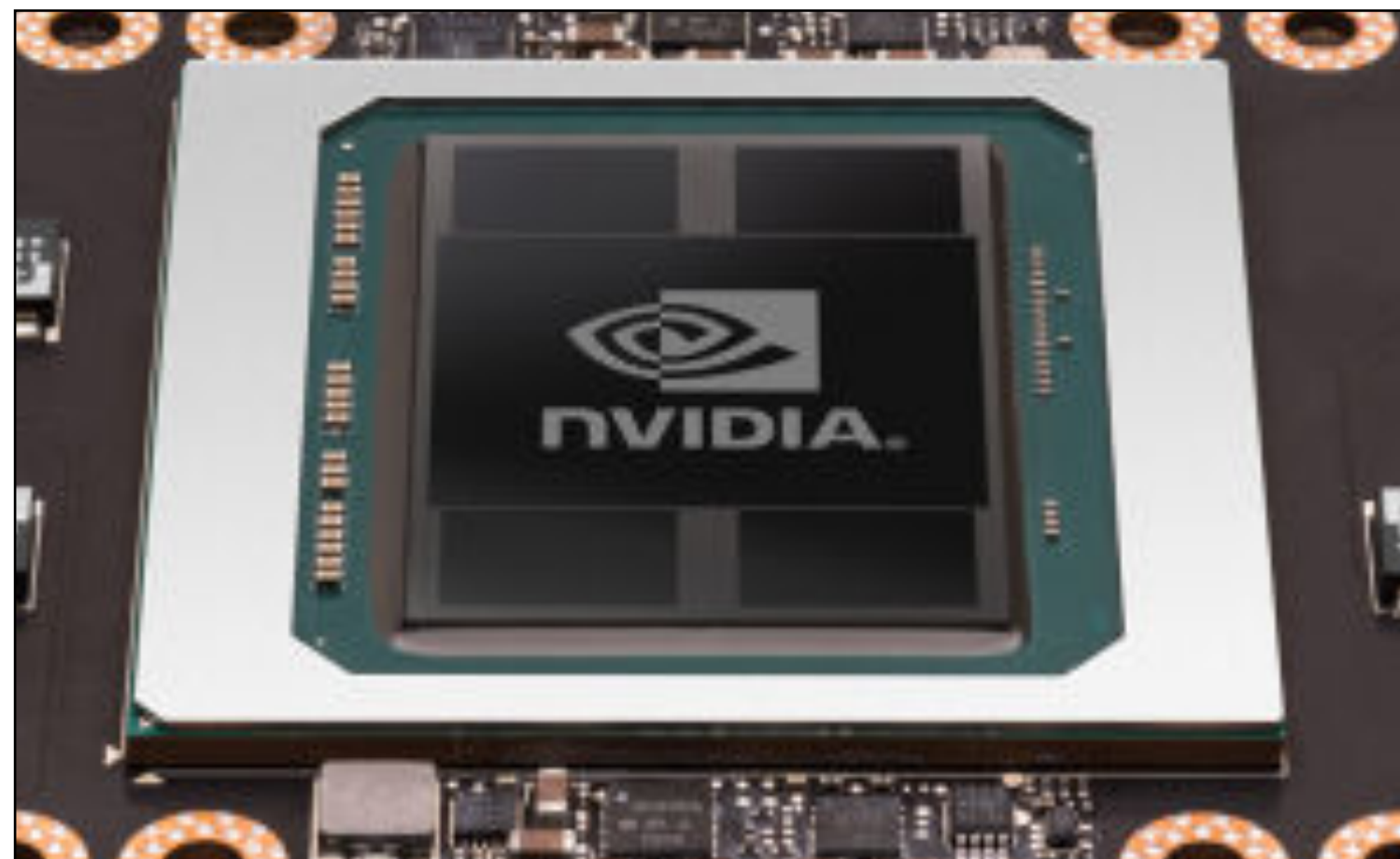
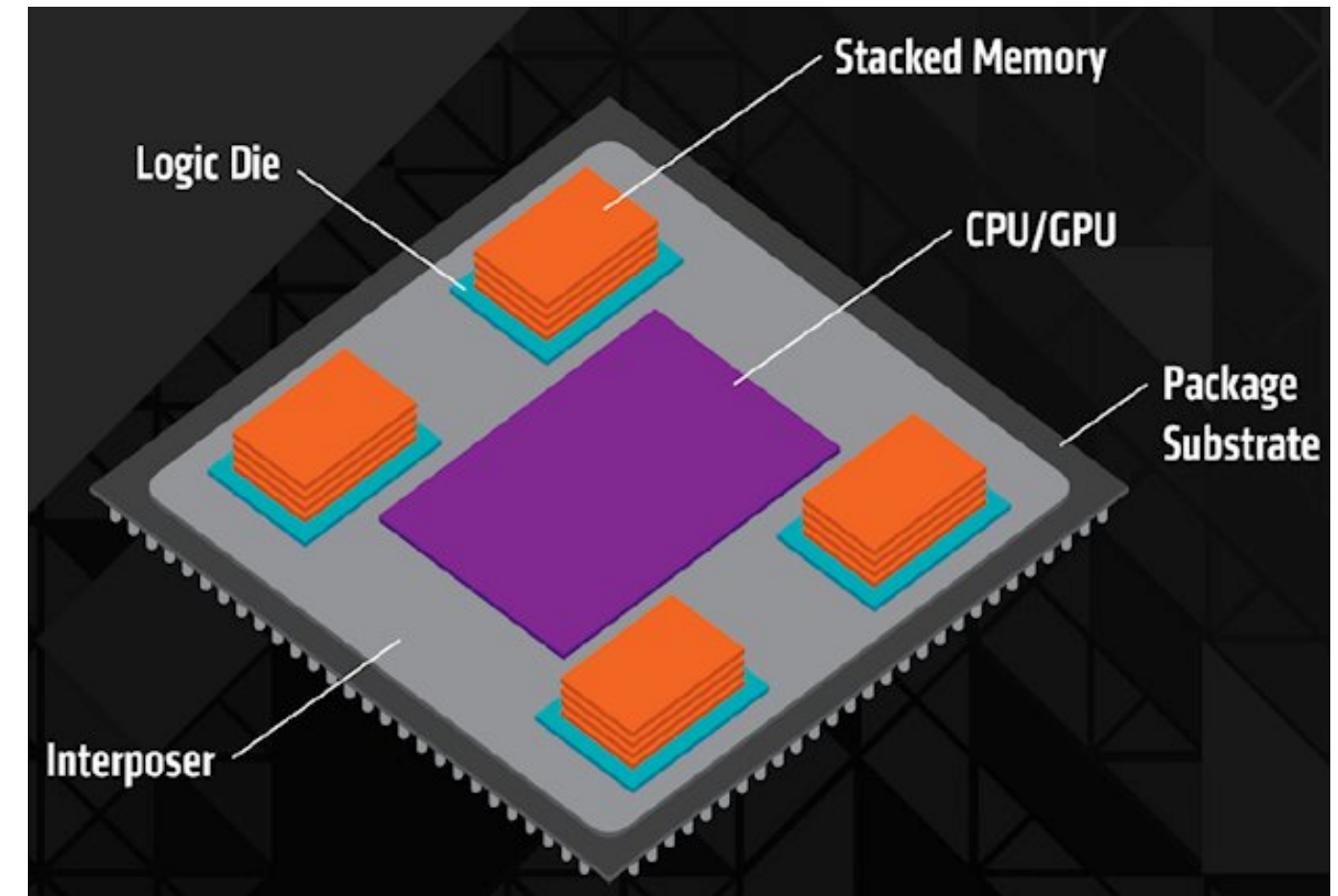
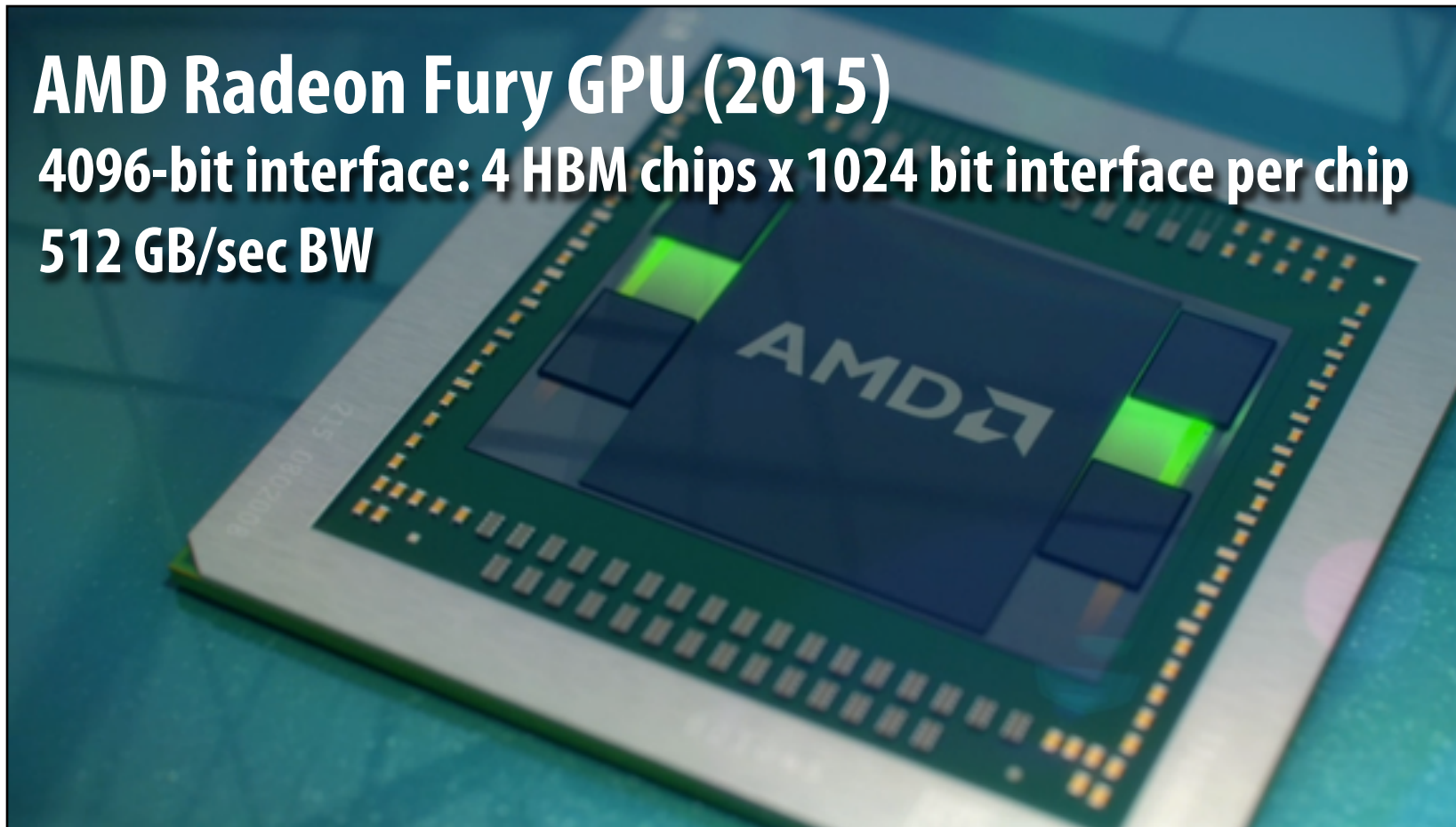

## NVIDIA P100 GPU (2016)

4096-bit interface: 4 HBM2 chips x 1024 bit interface per chip  
720 GB/sec peak BW  
4 x 4 GB = 16 GB capacity

# Xeon Phi (Knights Landing) MCDRAM

- 16 GB in package stacked DRAM
- Can be treated as a 16 GB last level cache
- Or as a 16 GB separate address space (“flat mode”)
- Intel’s claims:
  - ~ same latency at DDR4
  - ~5x bandwidth of DDR4
  - ~5x less energy cost per bit transferred

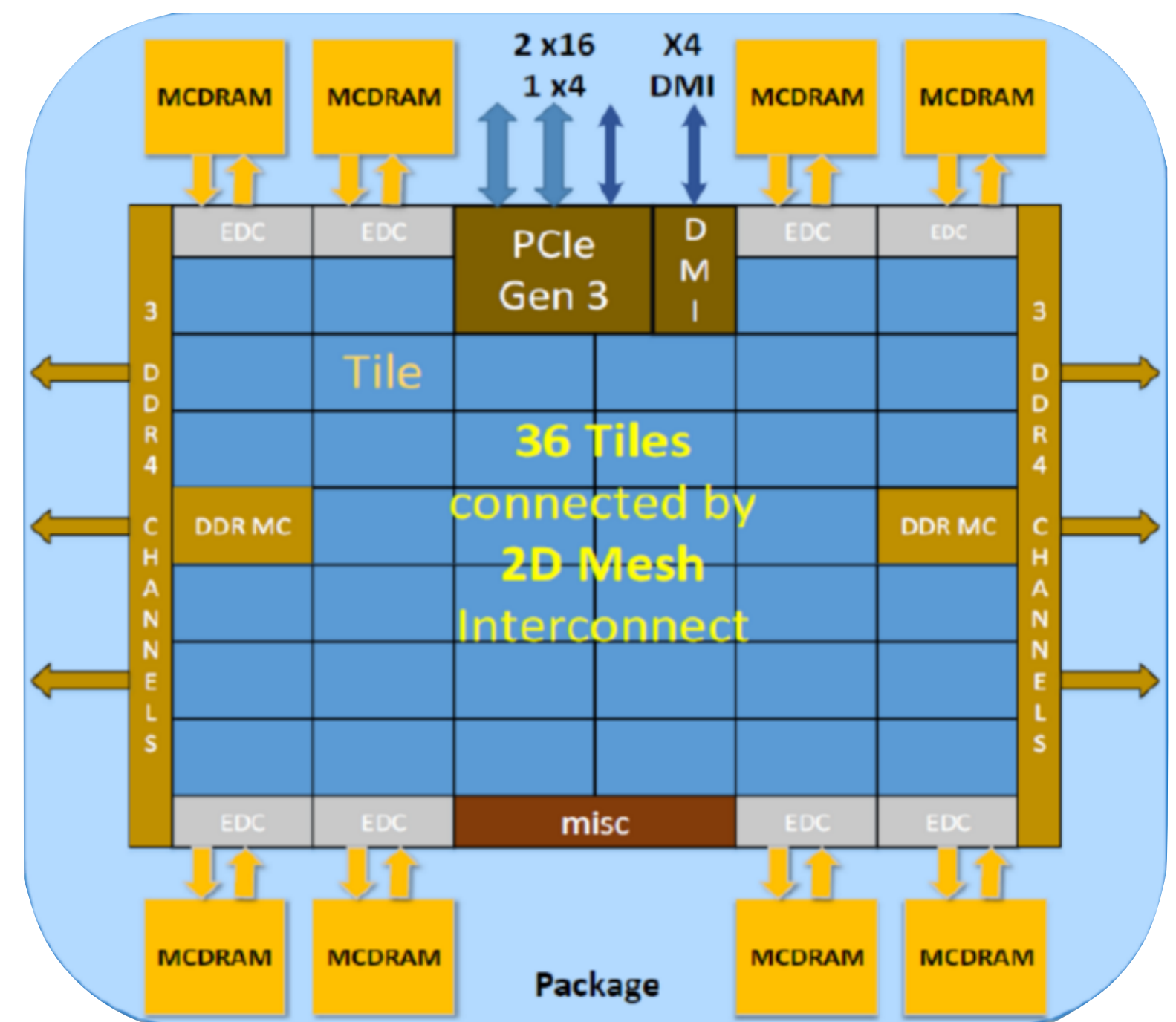

```
// allocate buffer in MCDRAM (“high bandwidth” memory malloc)
float* foo = hbw_malloc(sizeof(float) * 1024);
```



# Summary: the memory bottleneck is being addressed in many ways

## ■ By the application programmer

- Schedule computation to maximize locality (minimize required data movement)

## ■ By new hardware architectures

- Intelligent DRAM request scheduling
- Bringing data closer to processor (deep cache hierarchies, 3D stacking)
- Increase bandwidth (wider memory systems)
- Ongoing research in locating limited forms of computation “in” or near memory
- Ongoing research in hardware accelerated compression (not discussed today)

## ■ General principles

- Locate data storage near processor
- Move computation to data storage
- Data compression (trade-off extra computation for less data transfer)